

**ОКИСЛЕНИЕ ВОДОРАСТВОРЕННЫХ ХЕЛАТОВ ЖЕЛЕЗА (III)-КСИЛЕНОВОГО  
ОРАНЖЕВОГО ПЕРОКСИДОМ ВОДОРОДА: КОНЦЕПЦИЯ ГЕНЕРИРОВАНИЯ АТОМОВ  
СИНГЛЕТНОГО КИСЛОРОДА ИЗ ПЕРОКСИДА ВОДОРОДА**

**А.А. Чумаков, О.А. Котельников, Ю.Г. Слижов**

Антон Александрович Чумаков\*, Олег Алексеевич Котельников, Юрий Геннадьевич Слижов  
Химический факультет, Национальный исследовательский Томский государственный университет,  
просп. Ленина, 36, Томск, Российская Федерация, 634050  
E-mail: anton.doktor.tomsk@mail.ru\*, kot\_o\_a@mail.ru, decan@mail.tsu.ru

*Описывается впервые наблюдаемая реакция окисления пероксидом водорода водорастворённых хелатных комплексов индикатора ксиленолового оранжевого с ионами трёхвалентного железа. Реакция сопровождается обесцвечиванием фиолетового водного раствора комплексов (максимум поглощения 575 нм). Исходя из общепринятых представлений, реакция представляет собой процесс цепного свободнорадикального окисления молекул индикатора в водном растворе. Однако, в результате исследования продукта (обесцвеченного раствора) методом спектроскопии протонного ядерного магнитного резонанса была обнаружена модифицированная, но не разрушенная структура, углеводородный скелет которой в значительной степени сохранился в сравнении с исходным строением. Мы пришли к заключению, что в системе произошла не цепная свободнорадикальная деструкция индикатора, а его окислительная функционализация пероксидом водорода. В качестве ступеней процесса аргументированы N-окисление, элиминирование по Коуну и несколько изомеризаций с вероятной олигомеризацией первичных продуктов. Возникла необходимость объяснения механизма взаимодействия ионов трёхвалентного железа с молекулами пероксида водорода и обоснования природы промежуточных активных форм кислорода. Генерирование ионом железа (III) гидропероксильного радикала  $\text{HO}_2^\bullet$  из  $\text{H}_2\text{O}_2$  исключается по электрохимическим критериям. Анализ литературных данных позволил выявить сходство железом (III)-катализируемого гидропероксидного окисления ксиленолового оранжевого с пероксигеназа-катализируемыми биохимическими реакциями окислительной функционализации органических субстратов. Ферментативные реакции интерпретируются через генерирование четырёхвалентной формы железа. Проведя углубленный литературный анализ и моделирование молекулярно-орбитальных перестроек, мы предположили другую схему взаимодействия в системе  $\text{Fe}^{3+}/\text{H}_2\text{O}_2$ , а именно, цвиттер-ионизацию пероксида водорода (изомеризацию в молекулу оксидов  $\text{H}_2\text{O}^+-\text{O}^-$ ) с последующим внутримолекулярным диспропорционированием оксидов, генерирующим молекулу воды и атом синглетного кислорода  $\text{O}([\uparrow\downarrow][\uparrow\downarrow])$  или  $\text{O}([\uparrow\downarrow][\uparrow\downarrow][\_])$ . При этом ион железа, наиболее вероятно, не меняет степень окисления в ходе реакции и остаётся трёхвалентным. Окислительная функционализация органических субстратов пероксидом водорода в присутствии катализаторов на основе трёхвалентного железа предполагается перспективным подходом в органическом синтезе. При этом использование органических лигандов как компонентов железом (III)-содержащих катализаторов (применение хелатов в качестве катализаторов) лимитируется, так как требует избегания самоокисления комплексов применением лигандов, устойчивых к окислению. С другой стороны,*

*можно обозначить такую стратегию органического синтеза, как связывание функционализируемого субстрата в хелатный комплекс с катализатором – ионом трёхвалентного железа. Иными словами, получение требуемого продукта будет достигаться окислением исходного субстрата, находящегося в качестве лиганда в составе хелатного комплекса с ионом-катализатором.*

**Ключевые слова:** ксиленоловый оранжевый, трёхвалентное железо, пероксид водорода, декolorация, оксифункционализация, активные формы кислорода, оксидов, синглетный кислород

## OXIDATION OF FERRIC XYLENOL ORANGE CHELATES BY HYDROGEN PEROXIDE IN AQUEOUS SOLUTION: CONCEPTION OF OXYGEN SINGLET ATOMS GENERATION FROM HYDROGEN PEROXIDE

A.A. Chumakov, O.A. Kotelnikov, Yu.G. Slizhov

Anton A. Chumakov \*, Oleg A. Kotelnikov, Yuriy G. Slizhov

The Department of Chemistry, National Research Tomsk State University, Lenina ave., 36, Tomsk, 634050, Russia  
E-mail: anton.doktor.tomsk@mail.ru\*, kot\_o\_a@mail.ru, decan@mail.tsu.ru

*We observed for the first time the reaction of oxidation of ferric xylenol orange chelates by hydrogen peroxide in aqueous solution. The reaction is accompanied with decoloration of the violet aqueous solution. Based on generally accepted conception, there is a process of free radical chain oxidation of indicator molecule in the solution. However, after investigating the final colorless solution by 1H NMR-spectroscopy we found the modified but not broken structure in which the initial hydrocarbon core remained mainly unchanged. We concluded that kind of reaction was an oxyfunctionalization by hydrogen peroxide versus free radical chain destruction. We argued steps of the reaction such as N-oxidation, Cope's elimination, and certain rearrangements with possible products oligomerization. There was a need to explain the mechanism of interaction between the ferric iron ion and the hydrogen peroxide molecule and to argue the nature of intermediate reactive oxygen species. There is similarity between the ferric-catalyzed hydroperoxide xylenol orange oxidation and the peroxygenase-catalyzed biochemical oxyfunctionalization reactions. However, based on literature data and molecular orbital modeling, we proposed another mechanism of interaction between the ferric iron ion and the hydrogen peroxide molecule instead the tetravalent iron generation. Concretely, we proposed the hydrogen peroxide zwitter-ionization (isomerization to oxywater molecule) and subsequent intramolecular disproportionation with generation of a water molecule and a singlet oxygen atom as a reactive oxygen species. In this view, the iron ion oxidation state is unchanged during the reaction and remains ferric. An oxyfunctionalization of any organic substrate by hydrogen peroxide in the presence of ferric iron ions is promising approach in organic synthesis. However, the usage of organic ligands for ferric iron ions as components of catalysts is limited and requires only non-oxidizable compounds. On the other hand, one can choose an oxidation substrate as a ligand for ferric iron ions that is the formation of chelate complex of ferric catalyst with an organic substrate.*

**Key words:** xylenol orange, ferric iron, hydrogen peroxide, decoloration, oxyfunctionalization, reactive oxygen species, oxywater, singlet oxygen

### Для цитирования:

Чумаков А.А., Котельников О.А., Слизов Ю.Г. Окисление водорастворенных хелатов железа (III)-ксиленолового оранжевого пероксидом водорода: концепция генерирования атомов синглетного кислорода из пероксида водорода. *Иzv. вузов. Химия и хим. технология.* 2018. Т. 61. Вып. 2. С. 15–22

### For citation:

Chumakov A.A., Kotelnikov O.A., Slizhov Yu.G. Oxidation of ferric xylenol orange chelates by hydrogen peroxide in aqueous solution: conception of oxygen singlet atoms generation from hydrogen peroxide. *Izv. Vyssh. Uchebn. Zaved. Khim. Khim. Tekhnol.* 2018. V. 61. N 2. P. 15–22

## INTRODUCTION

The xylenol orange indicator ability to ferric iron ions chelation with violet coloration of solution is known to use in FOX-method (ferrous oxidation in xylenol orange) for measurement of hydroperoxides [1,2]. We observed for the first time the reaction of oxidation of ferric xylenol orange chelates by hydrogen peroxide in aqueous solution. The reaction is accompanied with decoloration of solution. The purpose of our study was to investigate the oxidation mechanism. Based on the experimental results and the literature date accompanied with molecular orbital modeling, we argued for a new conception of ferric iron ion interaction with hydrogen peroxide molecule.

## MATERIALS AND METHODS

**Chemicals:** Xylenol Orange disodium salt (Sigma-Aldrich), ferric chloride, hydrogen peroxide, distilled water. **Equipment:** Spectrophotometer SF-56 (Russia), NMR-Spectrometer Bruker Avance III HD.

## RESULTS

The xylenol orange aqueous solution  $5 \cdot 10^{-5}$  mol/l has a yellow color and absorbs visible light with  $\lambda_{\max} = 430$  nm (Fig. 1, spectrum 1). When equimolar amount of iron (III) chloride added, the violet color  $\lambda_{\max} = 575$  nm is appeared (Fig. 1, spectrum 2). The violet color is stable for many months. When hydrogen peroxide added, the decoloration of solution occurs very quickly within a few minutes (Fig. 1, spectra 3-5).

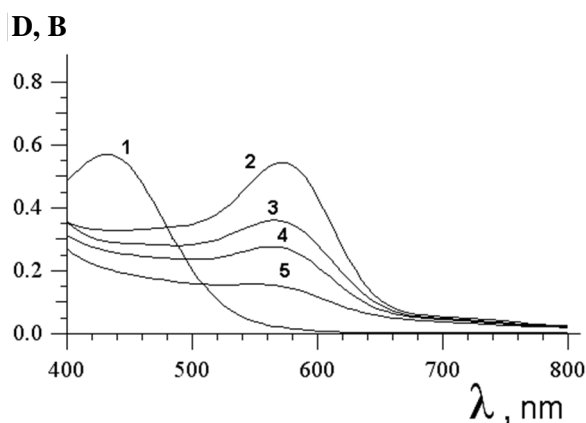

Fig. 1. Absorption spectra of xylenol orange aqueous solution (1), ferric indicator chelates solution (2), and decoloration of chelates solution by  $H_2O_2$  (3-5)

Рис. 1. Спектры поглощения водных растворов индикатора ксиленолового оранжевого (1) и его желез(III)-комплексов (2), и обесцвечивание раствора хелатов пероксидом водорода (3-5)

The monitoring in kinetic mode revealed a direct correlation between the reaction rate and the hydrogen peroxide concentration in solution (Fig. 2).

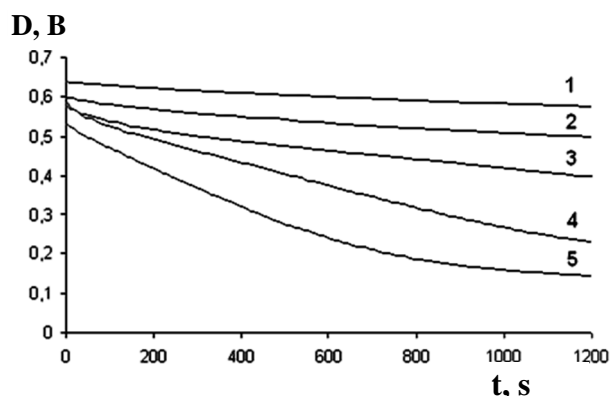

Fig. 2. The monitoring of decoloration rate ( $\lambda=575$  nm) at different hydrogen peroxide concentrations (mmol/l) in solution: 1 – 0.25 (5:1), 2 – 0.50 (10:1), 3 – 1.00 (20:1), 4 – 2.50 (50:1), 5 – 5.00 (100:1). The ratio in brackets means « $H_2O_2$ :chelate» (the chelate concentration is 0.05 mmol/l)

Рис. 2. Наблюдение скорости обесцвечивания ( $\lambda=575$  нм) при разных концентрациях пероксида водорода (ммоль/л) в растворе: 1 – 0,25 (5:1), 2 – 0,50 (10:1), 3 – 1,00 (20:1), 4 – 2,50 (50:1), 5 – 5,00 (100:1). Соотношение в скобках означает « $H_2O_2$ :хелаты» (концентрация комплексов 0,05 ммоль/л)

We examined the structure of reaction products by  $^1H$  NMR-spectroscopy with water spectrum suppression: the specific triphenylmethane fragment, methylene and methyl groups were reliably identified (Fig. 3).

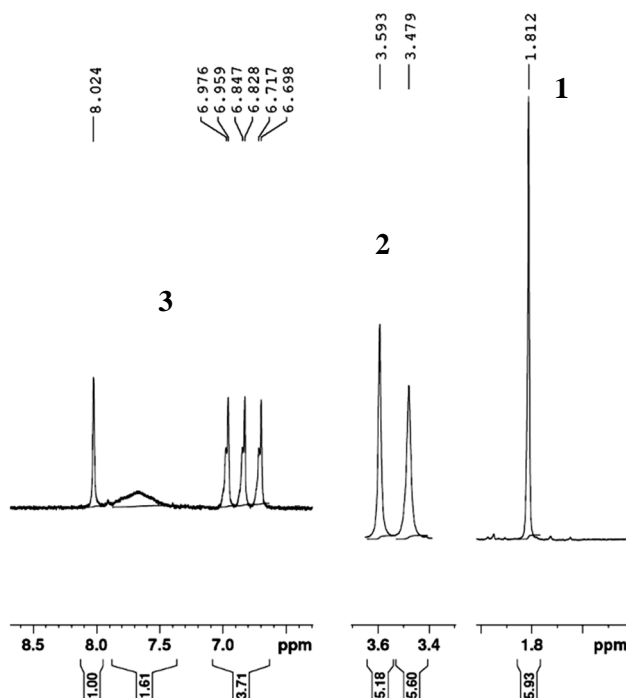

Fig. 3. The  $^1H$  NMR-spectrum of colorless solution after the oxidation with identification of product structure fragments: 1 – methyl group, 2 – methylene groups, 3 – aromatic fragment with triphenylmethane nucleus

Рис. 3. Спектр протонного магнитного резонанса обесцвеченного в результате окисления раствора с идентификацией структурных фрагментов продуктов: метильная группа (1), метиленовые группы (2), ароматический фрагмент с трифенилметановым ядром (3)

## DISCUSSION

The chelation of ferric ions by xylenol orange occurs, most likely, with participation of carboxylate, phenolate groups and tertiary nitrogen atoms with unshared pairs of electrons. Based on generally accepted conception [3,4], the interaction of ferric iron ion with hydrogen peroxide molecule occurs as one-electron redox reaction in which the ferric ion is an oxidant:



The reduction of iron to ferrous leads to a classical Fenton reaction:



Thus, the cyclic alternation of iron oxidation state determines a free radical chain oxidation by generation of hydroperoxyl (Equation 1) and hydroxyl (Equation 2) free radicals:

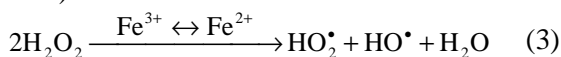

However, there are two arguments against such interpretation. First, our results revealed that the initial hydrocarbon core of organic molecule remained mainly unchanged. This is in contradiction with free radical chain oxidation, which usually results in complete decomposition of all organic compounds to carbon dioxide and water [4]. Second, when comparing the values of standard electrode potentials [5,6], one can conclude that the iron ion in ferric oxidation state is not able to oxidize the hydrogen peroxide molecule:

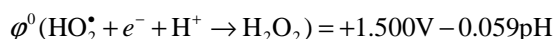
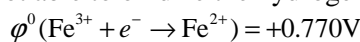

Therefore, the Reaction 1 occurs backwards. We made the thorough literature review in searching the alternative explanation of mechanism of interaction between the ferric iron ion and the hydrogen peroxide molecule. In result, we found that there are enzymes in biological nature, which have the ferric protoporphyrin IX (PPIX) complex at their active sites and use the hydrogen peroxide during certain biochemical processes. Such enzymes are [7], for example, catalase EC1.11.1.6, horseradish peroxidase EC1.11.1.7, L-ascorbate peroxidase EC1.11.1.11, mushroom peroxygenase EC1.11.2.1, myeloperoxidase EC1.11.2.2. Their catalytic cycle is accepted [8] to include the generation of complex of oxoferryl(IV) with  $\pi$ -radical-cation of protoporphyrin IX:



One can notice that mechanism is not simple and, most likely, stepwise because it includes a proton migration and two electrons transfer. With this, the source of second electron is a ligand surrounding of iron ion (PPIX). The oxoferryl (IV) cation is proposed

to be an active intermediate-oxidant, which further oxidizes a second hydrogen peroxide molecule for catalase CAT [9]:

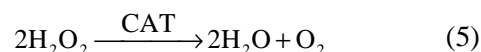

or oxidizes two phenolic substrates ArOH to phenoxyl radicals ArO $\bullet$  for horseradish peroxidase HRP [7]:

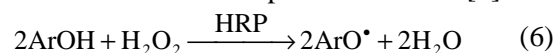

or oxidizes two L-ascorbate molecules C<sub>6</sub>H<sub>7</sub>O<sub>6</sub><sup>-</sup> to monodehydroascorbate radicals C<sub>6</sub>H<sub>7</sub>O<sub>6</sub><sup>\bullet</sup> for corresponding enzyme EC1.11.1.11 [7]:

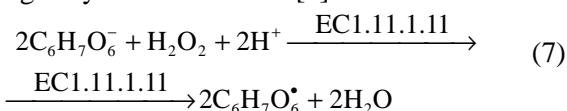

or oxidizes any organic substrate R to its oxyderivative RO for mushroom peroxygenase EC1.11.2.1 [7,10]:

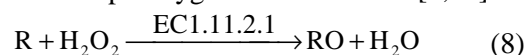

or oxidizes chloride to hypochlorite for myeloperoxidase MPO [11]:

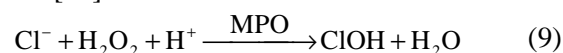

We adapted the Equation 8 for our reaction system. The xylenol orange molecule is a tertiary amine compound RN(CH<sub>2</sub>COO<sup>-</sup>)<sub>2</sub>. The nitrogen atom is the most likely target for oxidation. The N-oxide is generated:

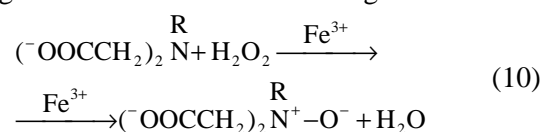

Further, we proposed the Cope elimination (Fig. 4). The rearrangements of Cope elimination products evidently result in the amavadin-like [12] ferric chelate with two N-oxyiminodiacetate ligands and the triphenylmethane derivative with two *ortho*-quinone methide fragments (Fig. 4). Quinone methides are highly reactive compounds, which are employed in organic synthesis as substrates and intermediates [13]. Although quinone methides are formally neutral molecules, the zwitter-ionic aromatic resonance structures are highly relevant, rendering these molecules highly polarized and thus reactive at those sites [13]. Hence, we proposed a further transformation of triphenylmethane derivative through its oligomerization by *ortho*-quinone methide fragments (Fig. 4). The degree of oligomerization cannot be precisely determined and, most likely, varies.

The substantiation of formation of amavadin-like ferric chelates and triphenylmethane oligomers (Fig. 4) is in very good agreement with <sup>1</sup>H NMR-spectroscopy results (Fig. 3).

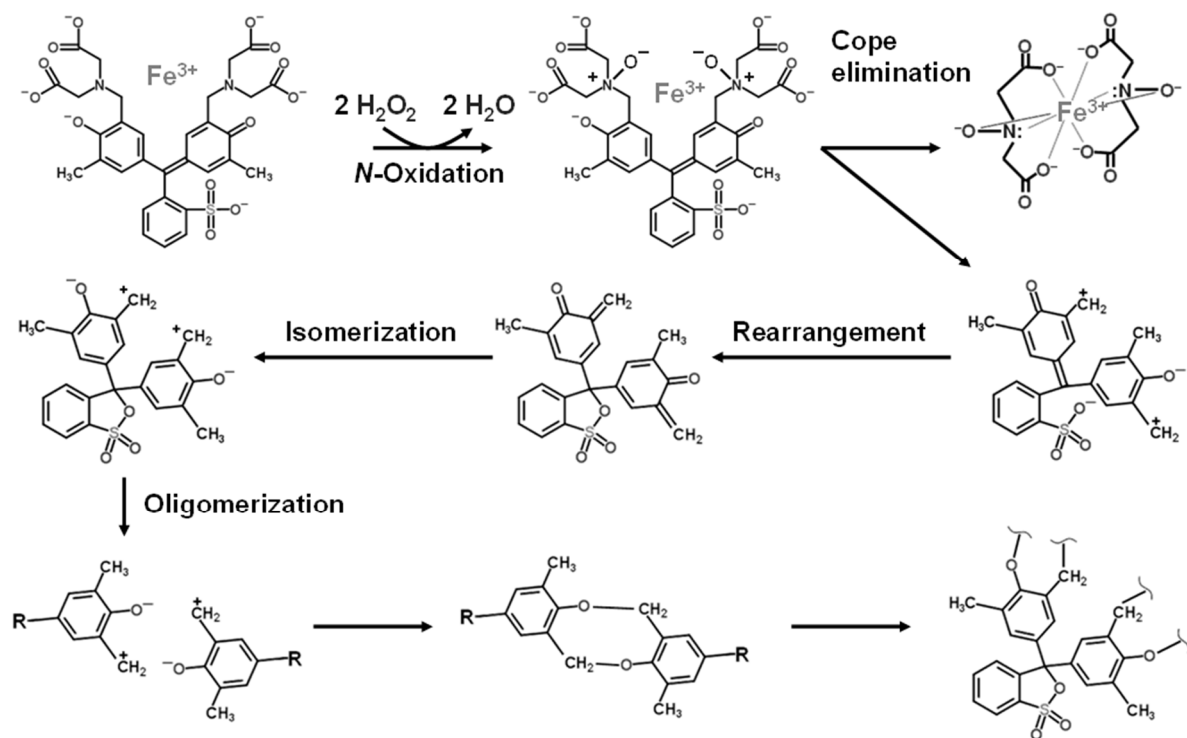
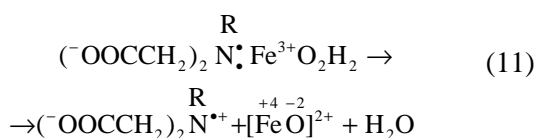
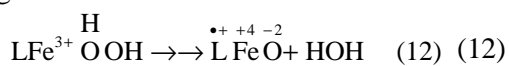

Fig. 4. The proposed mechanism of ferric xylenol orange chelates oxidation  
 Рис.4. Предполагаемый механизм окисления хелатных комплексов железа(III)-ксиленолового оранжевого

However, the mechanism of interaction between the ferric iron ion and the hydrogen peroxide molecule (Equation 10) remained unclear. It would be possible to adjust the conception of oxoferryl (IV) generation (Equation 4) with formation of nitrogen-centered radical-cation:



However, in our opinion, such interpretation, at one side, is complicated by an idea of high-valent iron generation and ligand L oxidation and, on the other hand, if it is true it requires the detalization because of including a proton migration and two electrons transfer:



It should be noted that an idea of ligand surrounding oxidation is not suitable universally for all ferric hydrogen peroxide systems. For instance, it not adjustable to simplest ones:

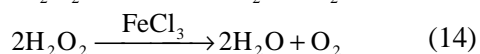
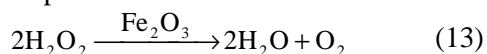

One can easily ensure that ferric oxide and ferric chloride catalyze a hydrogen peroxide disproportionation but it is unlikely an oxide or chloride ligand reversible oxidation:

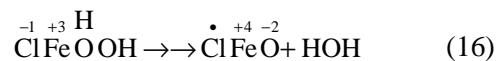
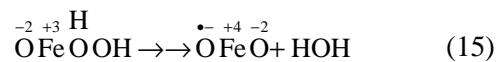

The *Sugimoto H.* with colleagues [14] proposed that ferric chloride activates the hydrogen peroxide without iron oxidation state changing and with oxene generation:

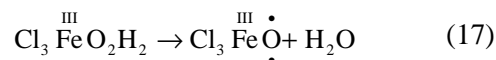

The *Schaefer H.F.III* with colleagues [15,16] proposed the isomerization of hydrogen peroxide to oxywater molecule:

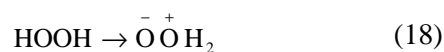

Any experimental verification of the oxywater existence has not got until now but there are some theoretical publications with quantum chemical calculations of hydrogen peroxide/oxywater isomerization [17,18] and photodissociation of oxywater [19]. The *Loew G.H.* with colleagues [20-22] proposed the hydrogen peroxide zwitter-ionization as a first step of peroxidases catalytic cycle followed by oxoferryl (IV) generation (Equation 4). According to calculations, the gas-phase isomerization is highly endothermic and possesses large activation energy but the metal ion significantly stabilizes the oxywater [20].

We accepted the conception of the hydrogen peroxide zwitter-ionization to oxywater molecule and

proposed a participation of water molecule in proton transfer with intermediate generation of a hydronium cation (Fig. 5).

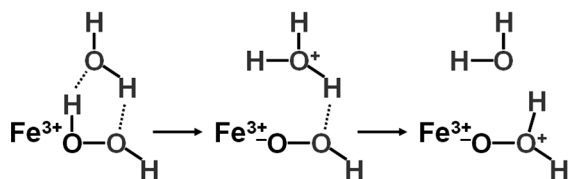
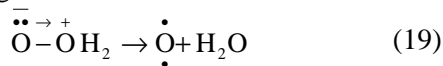

Fig. 5. The proposed mechanism of hydrogen peroxide isomerization to oxywater

Рис. 5. Предполагаемый механизм изомеризации пероксида водорода в оксигводу

In our opinion, the next step of hydrogen peroxide activation is an intramolecular disproportionation because of appearance of two opposite charges on neighboring oxygen atoms:



This view is in accordance with the assumption of Sugimoto H. with colleagues [14], see Equation 17,

and with an idea of oxywater dissociation into water and singlet oxygen atom [19].

We constructed the scheme of molecular orbital system for hydrogen peroxide molecule, further simulated a hydrogen peroxide zwitter-ionization with subsequent intramolecular disproportionation and confirmed a singlet quantum state of generated oxygen atom (Fig. 6).

Thus, we substantiated the next mechanism of xylenol orange *N*-oxidation:

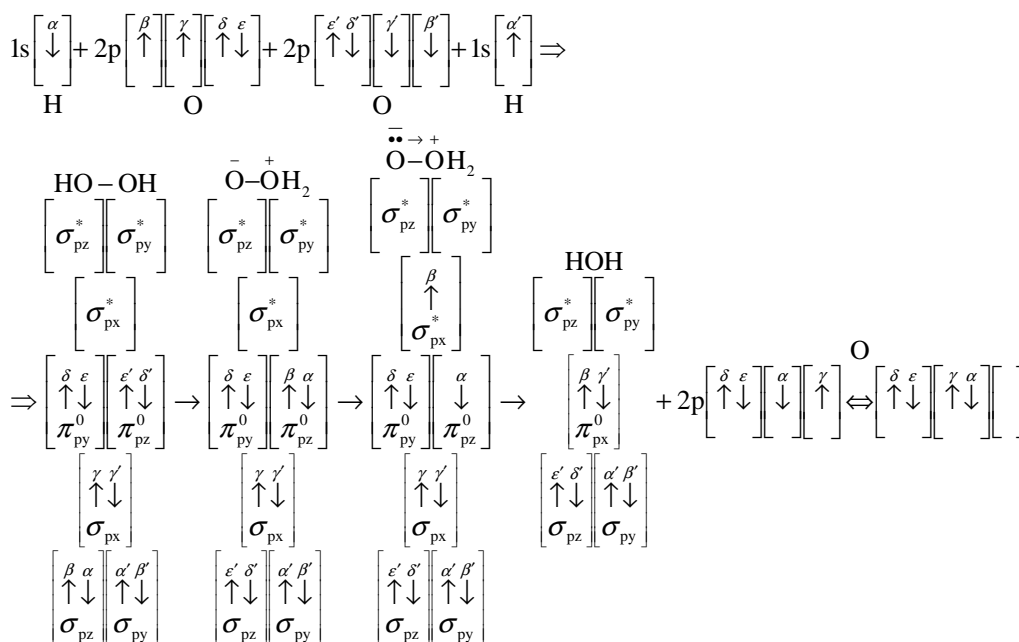
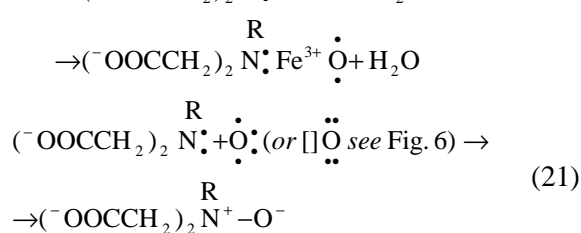
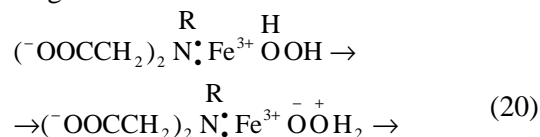
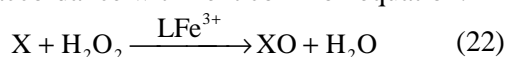

Fig. 6. The modeling of hydrogen peroxide zwitter-ionization with subsequent oxywater intramolecular disproportionation

Рис. 6. Моделирование цвиттер-ионизации пероксида водорода и последующего внутримолекулярного диспропорционирования оксигводы

The chelates of different organic ligands L with ferric iron ions was shown to be the catalysts of organic substrates X oxyfunctionalization by  $\text{H}_2\text{O}_2$  [23-26] in accordance with next common equation:



Our results support the ability of  $\text{Fe}^{3+}/\text{H}_2\text{O}_2$  systems to oxidize specifically the organic substrates but show that ligand L itself may be susceptible to oxidation that is  $\text{L}=\text{X}$ . At one side, the choice of non-oxi-

dizable ligands is needed. On the other hand, it is possible to create chelates of ferric catalyst with an oxyfunctionalization substrate:

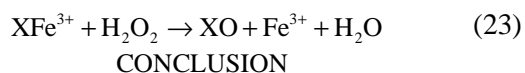

#### CONCLUSION

The oxidation of ferric xylenol orange chelates by hydrogen peroxide is oxyfunctionalization reaction and not free radical chain destruction. The proposed mechanism includes steps such as *N*-oxidation, Cope elimination, and certain rearrangements with possible products oligomerization.

The *N*-oxidation occurs through the activation of hydrogen peroxide molecule on the ferric iron ion with generation of reactive oxygen species. The nature of intermediate-oxidant is widely accepted in literature to be an oxygen free radical with one unpaired electron (hydroperoxyl) or an iron in tetravalent oxidation state (oxoferryl (IV) cation). However, the extremely limited number of scientific publications is found to support an alternative conception of ferric iron interaction with hydrogen peroxide such as hydrogen peroxide zwitter-ionization with subsequent intramolecular disproportionation. We accepted this view and proposed the singlet oxygen atom as reactive oxygen species generated from a hydrogen peroxide molecule by ferric iron ion. This intermediate is most likely oxidant of tertiary nitrogen atoms of xylenol orange indicator.

An oxidation of any organic substrate by hydrogen peroxide in the presence of ferric catalyst is promising approach in organic synthesis for oxyfunctionalization. The usage of organic ligands for ferric iron ions as components of catalysts requires only non-oxidizable compounds. On the other hand, it is possible to create chelate complexes of ferric catalyst with an oxyfunctionalization substrate as a ligand.

#### REFERENCES ЛИТЕРАТУРА

1. **Li D., Wang M., Cheng N., Xue X., Wu L., Cao W.** A modified FOX-1 method for Micro-determination of hydrogen peroxide in honey samples. *Food Chemistry*. 2017. V. 237. P. 225–231.
2. **Mehta B.M., Darji V.B., Aparnathi K.D.** Comparison of five analytical methods for the determination of peroxide value in oxidized ghee. *Food Chemistry*. 2015. V. 185. P. 449–453.
3. **Gonzalez-Olmos R., Holzer F., Kopinke F.-D., Georgi A.** Indications of the reactive species in a heterogeneous Fenton-like reaction using Fe-containing zeolites. *Appl. Catal. A: Gen.* 2011. V. 398. N 1–2. P. 44–53.
4. **Bokare A.D., Choi W.** Review of iron-free Fenton-like systems for activating H<sub>2</sub>O<sub>2</sub> in advanced oxidation processes. *J. Hazardous Mat.* 2014. V. 275. P. 121–135.
5. **Ter Heijne A., Hamelers H.V., De Wilde V., Rozendal R.A., Buisman C.J.** A bipolar membrane combined with ferric iron reduction as an efficient cathode system in microbial fuel cells. *Envir. Sci. Tech.* 2006. V. 40. N 17. P. 5200–5205.
6. **Koppenol W.H., Stanbury D.M., Bounds P.L.** Electrode potentials of partially reduced oxygen species, from dioxygen to water. *Free Radical Biology and Medicine*. 2010. V. 49. N 3. P. 317–322.
7. **McDonald A.G., Boyce S., Moss G.P., Dixon H.B., Tipton K.F.** ExplorEnz: a MySQL database of the IUBMB enzyme nomenclature. *BMC Biochemistry*. 2007. V. 8. Article 14.
8. **Ghosh A.** High-valent iron intermediates in biology. *J. Inorg. Biochem.* 2006. V. 100. N 4. P. 419–880.
9. **Kodydková J., Vávrová L., Kocík M., Žák A.** Human catalase, its polymorphisms, regulation and changes of its activity in different diseases. *Folia Biologica*. 2014. V. 60. N 4. P. 153–167.
10. **Ni Y., Fernández-Fueyo E., Gomez Baraibar A., Ullrich R., Hofrichter M., Yanase H., Alcalde M., van Berkel W.J., Hollmann F.** Peroxygenase-catalyzed oxyfunctionalization reactions promoted by the complete oxidation of methanol. *Angewandte Chemie*. 2016. V. 55. N 2. P. 798–801.
11. **Kato Y.** Neutrophil myeloperoxidase and its substrates: formation of specific markers and reactive compounds during inflammation. *J. Clinical Biochem. Nutrition*. 2016. V. 58. N 2. P. 99–104.
12. **da Silva J.A.L., Fraústo da Silva J.J.R., Pombeiro A.J.L.** Amavadin, a vanadium natural complex: Its role and applications. *Coordinat. Chem. Rev.* 2013. V. 257. N 15–16. P. 2388–2400.
13. **Caruana L., Fochi M., Bernardi L.** The emergence of quinone methides in asymmetric organocatalysis. *Molecules*. 2015. V. 20. N 7. P. 11733–11764.
14. **Sugimoto H., Spencer L., Sawyer D.T.** Ferric chloride-catalyzed activation of hydrogen peroxide for the demethylation of *N,N*-dimethylaniline, the epoxidation of olefins, and the oxidative cleavage of vicinal diols in acetonitrile: A reaction mimic for cytochrome P-450. *PNAS USA*. 1987. V. 84. N 7. P. 1731–1733.
15. **Meredith C., Hamilton T.P., Schaefer H.F.III.** Oxywater (water oxide): new evidence for the existence of a structural isomer of hydrogen peroxide. *J. Phys. Chem.* 1992. V. 96. N 23. P. 9250–9254.
16. **Huang H.H., Xie Y., Schaefer H.F.III.** Can oxywater be made? *J. Phys. Chem.* 1996. V. 100. N 15. P. 6076–6080.
17. **Jursic B.S.** Density functional theory and ab initio study of oxywater isomerization into hydrogen peroxide. *J. Molec. Struct.: Theochem*. 1997. V. 417. N 1–2. P. 81–88.
18. **Schwerdtfeger C.A., DePrince A.E.III, Mazziotti D.A.** Testing the parametric two-electron reduced-density-matrix method with improved functionals: Application to the conversion of hydrogen peroxide to oxywater. *J. Chem. Phys.* 2011. V. 134. N 17. Article 174102.
19. **Franz J., Francisco J.S., Peyerimhoff S.D.** Production of singlet oxygen atoms by photodissociation of oxywater. *J. Chem. Phys.* 2009. V. 130. N 8. Article 084304.

20. **Woon D.E., Loew G.H.** An ab initio model system investigation of the proposed mechanism for activation of peroxidases: cooperative catalytic contributions from the ion and microsolvated water. *J. Phys. Chem. A*. 1998. V. 102. N 50. P. 10380–10384.
21. **Filizola M., Loew G.H.** Role of protein environment in horseradish peroxidase compound I formation: molecular dynamics simulations of horseradish peroxidase–HOOH complex. *J. Am. Chem. Soc.* 2000. V. 122. N 1. P. 18–25.
22. **Filizola M., Loew G.H.** Probing the role of protein environment in compound I formation of chloroperoxidase (CPO). *J. Am. Chem. Soc.* 2000. V. 122. N 15. P. 3599–3605.
23. **Silva G.C., Carvalho N.M.F., Horn Jr.A., Lachter E.R., Antunes O.A.C.** Oxidation of aromatic compounds by hydrogen peroxide catalyzed by mononuclear iron(III) complexes. *J. Molec. Cat. A: Chem.* 2017. V. 426. Part B. P. 564–571.
24. **Wang Y., Wen X., Rong C., Tang S., Wu W., Zhang C., Liu Y., Fu Z.** Weakly distorted 8-quinolinolato iron(III) complexes as effective catalysts for oxygenation of organic compounds by hydrogen peroxide. *J. Molec. Cat. A: Chem.* 2016. V. 411. P. 103–109.
25. **Dutta A.K., Samanta S., Dutta S., Lucas C.R., Dawe L.N., Biswas P., Adhikary B.** Iron (III) complexes of 2-(1H-benzo[d]imidazol-2-yl)phenol and acetate or nitrate as catalysts for epoxidation of olefins with hydrogen peroxide. *J. Molec. Struct.* 2016. V. 1115. P. 207–213.
26. **Kejriwal A., Biswas S., Biswas A.N., Bandyopadhyay P.** cis-Dihydroxylation of electron deficient olefins catalysed by an oxo-bridged diiron (III) complex with H<sub>2</sub>O<sub>2</sub>. *J. Molec. Cat. A: Chem.* 2016. V. 413. P. 77–84.

*Поступила в редакцию 22.06.2017  
Принята к опубликованию 27.12.2017*

*Received 22.06.2017  
Accepted 27.12.2017*