

**Для цитирования:**

Шукуров А.Л., Манукян А.С., Шутов Д.А., Рыбкин В.В. Физико-химические свойства плазмы разряда постоянного тока с жидким катодом. *Изв. вузов. Химия и хим. технология*. 2016. Т. 59. Вып. 12. С. 4–16.

**For citation:**

Choukourov A., Manukyan A.S., Shutov D.A., Rybkin V.V. Physico-chemical properties of dc current discharge plasma with liquid cathode. *Izv. Vyssh. Uchebn. Zaved. Khim. Khim. Tekhnol.* 2016. V. 59. N 12. P. 4–16.

УДК: 537.528+541.15

**А.Л. Шукуров, А.С. Манукян, Д.А. Шутов, В.В. Рыбкин**

**ФИЗИКО-ХИМИЧЕСКИЕ СВОЙСТВА ПЛАЗМЫ РАЗРЯДА ПОСТОЯННОГО ТОКА С ЖИДКИМ КАТОДОМ**

*В статье анализируются результаты экспериментальных исследований и моделирования физико-химических характеристик плазмы разрядов постоянного тока с электролитным катодом при давлениях  $(1,01-0,101) \cdot 10^5$  Па, создаваемой в молекулярных и атомарных газах. Приводятся сведения о физических параметрах плазмы (напряженности электрических полей, катодные падения потенциала, газовые температуры). Анализируются результаты измерений и расчетов концентраций активных частиц, электронов, а также распределений молекул по колебательным уровням и функциям распределения электронов по энергиям.*

**Ключевые слова:** плазма, газовый разряд, физические параметры, активные частицы, механизмы процессов



**Андрей Леонидович  
Шукуров**  
Andrey L. Choukourov



**Анна Славиковна  
Манукян**  
Anna S. Manukyan



**Дмитрий Александрович  
Шутов**  
Dmitriy A. Shutov



**Владимир Владимирович  
Рыбкин (✉)**  
Vladimir V. Rybkin

Кафедра физики макромолекул, факультет математики и физики, Карлов университет в Праге, Голешовице, 2, Прага, Чехия, 180 00  
E-mail: choukourov@kmf.troja.mff.cuni.cz

Кафедра технологии приборов и материалов электронной техники, Институт термодинамики и кинетики химических процессов, Ивановский государственный химико-технологический университет, Шереметевский пр., 7, Иваново, Российская Федерация, 153000  
E-mail: ivkkt@isuct.ru, shutov@isuct.ru, rybkin@isuct.ru (✉)

Область научных интересов: Физика и химия плазмы, кинетика неравновесных процессов, взаимодействие плазмы с поверхностью

**A. Choukourov, A.S. Manukyan, D.A. Shutov, V.V. Rybkin**

Andrey L. Choukourov

Department of Macromolecular Physics, Faculty of Mathematics and Physics, Charles University in Prague, V Holesovickach 2, 180 00 Prague, Czech Republic  
E-mail: choukourov@kmf.troja.mff.cuni.cz

Anna S. Manukyan, Dmitriy A. Shutov, Vladimir V. Rybkin (✉)

Department of Electronic Devices and Materials, Ivanovo State University of Chemistry and Technology, Sheremetevskiy ave., 7, Ivanovo, 153000, Russia  
E-mail: rybkin@isuct.ru (✉), shutov@isuct.ru  
Institute of Thermodynamics and Kinetics of Chemical Processes

## PHYSICO-CHEMICAL PROPERTIES OF DC CURRENT DISCHARGE PLASMA WITH LIQUID CATHODE

*In article the results of experimental studies and modeling of physic-chemical parameters of plasma of DC current discharges with electrolyte cathode are analyzed at the pressure range of  $(1.01-0.101) \cdot 10^5$  Pa for molecular and atomic gases. The data on physical parameters of plasma (electric field strength, cathode voltage drop, gas temperatures) are given. The results of measurements and calculations of active species concentrations, electrons, as well as molecule distributions on vibrational levels and electron energy distribution functions are analyzed.*

**Key words:** plasma, gas discharge, physical parameters, active species, process mechanisms

### INTRODUCTION

Numerous studies published last ten years (see reviews [1-7]) on various aspects of high pressure non-equilibrium plasma created with gas discharges in water solutions or above their surface emphasize the increasing interest of researches to the given area of chemistry and physics of plasma. One of the reasons of that interest is the new possibilities which provide these discharges for practical application. To date, many applications were already tested. Among them biomedical applications (plasma scalpels, sterilization, wounds repair (NO-therapy), microsized sources of emission for analysis of water solutions containing the ion admixtures of metals (including heavy metals), modification of polymer surfaces, obtaining fullerenes, nano powders of semiconductors, and catalysts. There is successful experience on the discharge application for soil remediation and food treatment from pesticides [8, 9]. One of the promising directions of such discharge application is the use for organic substances degradation and removing ions of heavy metals (for example, Cr, Mn) contained in wastewaters. A plasma action is attractive since the plasma itself is a source of active species (for example, UV radiation,  $H_2O_2$ , molecules of

singlet oxygen, oxygen and hydrogen atoms,  $\cdot OH$  and  $HO_2$  radicals etc.). These particles are capable to manifest as oxidative as reduction properties depending on conditions. Another important peculiarity of processes in plasma systems is high rates at relatively low temperatures. This is due to the fact that plasma systems are non-equilibrium ones. The primary source of active species formation is not heat activation but processes with participation of electrons. Electrons gain the energy from external electric field and transform this energy colliding with atoms and molecules to the energy of excitation of various states and to dissociation. Further reactions of particles being formed provide the formation of other active particles.

In the given paper the properties, peculiarities and possibilities of plasma forming at DC discharge burning above a surface of water or water solution, which serve as cathodes of the discharge, will be considered.

### REACTOR DESIGN. MAIN PHYSICAL PROPERTIES

The typical sketch of reactor for creation and study of DC discharge properties is shown in Fig. 1 [10-13]. The discharge is created by applying a DC high voltage (~several kV) between metal anode (4)

and water solution. The cell with solution can be thermo stabilized and include the mixer. The solution flow is also possible.

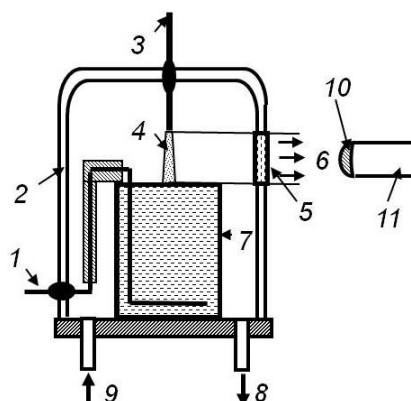

Fig. 1. The schematic diagram of the experimental set-up. 1 – cathode, 2 - glass bell-jar, 3 – anode, 4 – discharge, 5 - quartz window, 6 – radiation output to entrance lens of light fiber, 7 – glass cell with solution, 8,9 – gas outlet and inlet, 10 - entrance lens of light fiber, 11- light fiber

Рис. 1. Схема экспериментального реактора. 1 – катод, 2 – вакуумный колпак, 3 – анод, 4 – разряд, 5 – кварцевое окно, 6 – выход излучения, собираемого световодом, 7 – ячейка с раствором, 8,9 – вход и выход газа, 10 – входная линза световода, 11 – световод

The discharge image is glowing cone in the base of which the cathode spot is situated with the diameter of  $D_c$ . The area of cathode voltage drop abuts upon this spot (Fig. 2).

Geometrical parameters of discharge cone depend on the discharge current. At given pressure with the current increase the radius of cathode spot and radius at height  $H$  (Fig. 2) depends linearly on the discharge current. At fixed current the discharge dimensions decrease with the pressure growth (Fig. 3). Also, the radius depends on a kind of plasma-forming gas. Thus, at atmospheric pressure the radius is increased from 1.42 to 1.8 mm at the current change from 10 to 30 mA for air discharge, from 0.4 to 0.6 mm for argon discharge and from 0.08 to 0.2 mm for helium discharge.

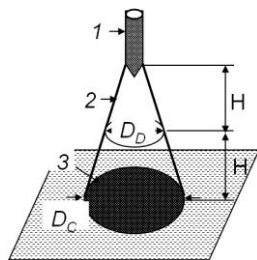

Fig. 2. The discharge view. 1 – anode, 2 – discharge, 3 – cathode spot on the solution surface

Рис. 2. Вид разряда. 1- анод, 2 – разряд, 3 – катодное пятно на поверхности раствора

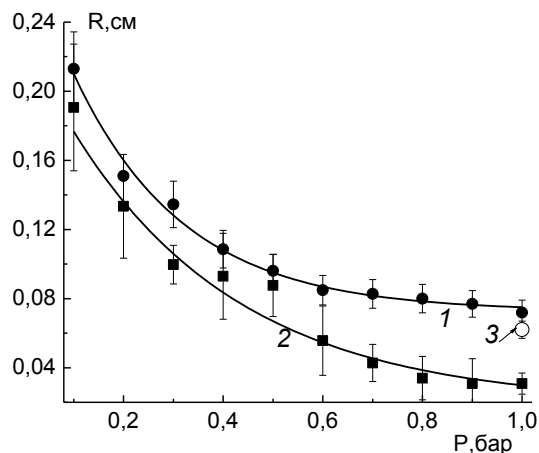

Fig. 3. The dependence of discharge radius at height of  $H$  on the pressure. 1,3 –  $N_2$  [12,14], 2 –  $O_2$  [13]. The discharge current is 40 mA

Рис. 3. Зависимость радиуса разряда на высоте  $H$  от давления. 1,3 –  $N_2$  [12,14], 2 –  $O_2$  [13]. Ток разряда 40 мА

Forming discharge is very close to normal glow discharge of low pressure on own parameters.

1) Discharge has the space of cathode voltage drop contacting directly with a water surface [15-19]. But values of cathode drops,  $U_c$ , are essentially higher than for discharges with metal cathodes. For metal cathodes, the  $U_c$  values are less than  $\sim 300$  V [6], whereas for cathode from distilled water they lie in the range of 400-750 V (Fig. 4, [16]). Therefore,  $\gamma$ -emission coefficient for water system is less than for metals.

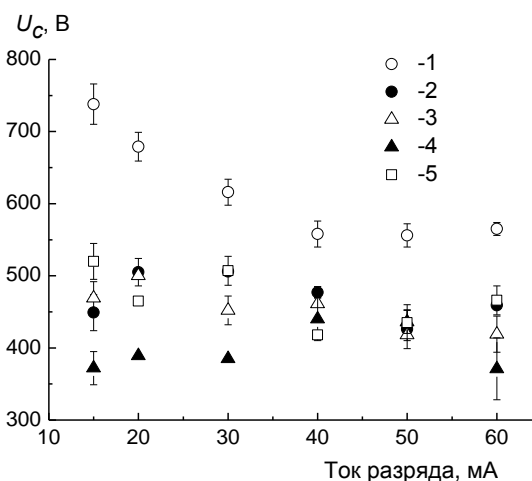

Fig. 4. The cathode voltage drop vs discharge current for distilled water (1) and KCl solutions. 2,3,4,5 – KCl concentrations are 0.08, 0.25, 0.42 and 0.5 mol/l, respectively. Plasma-forming gas is ambient air

Рис. 4. Катодное падение потенциала как функция тока разряда для дистиллированной воды (1) и растворов KCl. 2,3,4,5 – концентрации растворов 0,08, 0,25, 0,42 и 0,5 моль/л соответственно. Плазмообразующий газ-воздух

Unlike discharges of low pressure where  $U_c$  does not depend on the discharge current, for the discharge with liquid cathode the trend of  $U_c$  dropping is clearly observed under the current increase. The fact is that at discharge action on water, other substances are formed, partially, hydrogen peroxide [20]. And at every current value we deal with the cathode of different chemical nature. This fact is confirmed by  $U_c$  change at addition to water of different salts. The  $U_c$  value depends also on the kind of plasma-forming gas. It decreases from 719 to 426 V in series of air,  $N_2$ ,  $N_2O$ , He,  $O_2$ ,  $CO_2$  and Ar at the discharge current of 25 mA [13, 21]. The discharge current increase results in the reduction of cathode drop and in the increase in a diameter of cathode spot. When this diameter reaches the vessel diameter, the discharge transfers to abnormal form as it takes place for the discharge of low pressure. The cathode drop starts growing with the discharge current [22].

2) The discharge structure is the same as for glow discharge at low pressure. It includes cathode drop, negative glowing, Faraday's dark space, positive column and anode glowing [15, 23, 26].

3) Electric field strength,  $E$ , is constant within positive column (in plasma) [15, 18, 24, 25].  $E$  values depend on the discharge current, pressure and plasma-forming gas kind and less on electrolyte composition (Fig. 5-6).

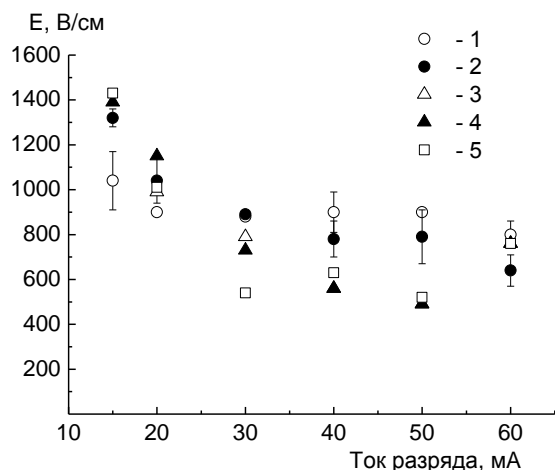

Fig. 5. The electric field strength in a plasma vs discharge current for distilled water (1) and KCl solutions. 2,3,4,5 – KCl concentrations are 0.08, 0.25, 0.42 and 0.5 mol/l, respectively. Plasma-forming gas is ambient air

Рис. 5. Напряженность поля в плазме как функция тока разряда для дистиллированной воды (1) и растворов KCl. 2,3,4,5 – концентрации растворов 0,08, 0,25, 0,42 и 0,5 моль/л соответственно. Плазмообразующий газ – воздух

4) Like normal discharge of low pressure the discharge current density doesn't depend on the discharge current at given pressure [15, 19].

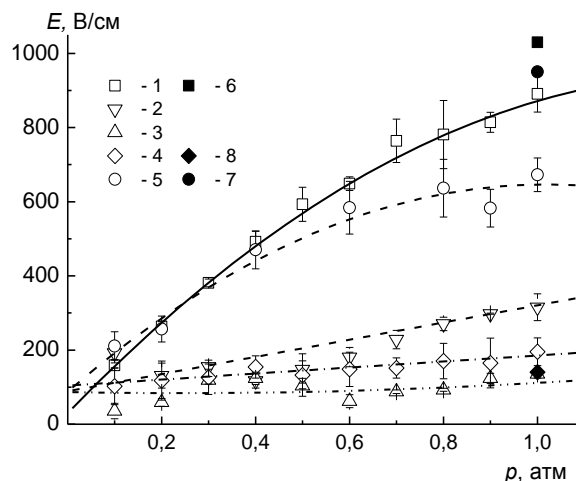

Fig. 6. The electric field strength vs pressure. 1-  $N_2$ , 2 -  $O_2$ , 3 - Ar+2%  $N_2$ , 4 - Ar, 5 - air. 6, 7, 8 - for  $N_2$ , air, and Ar on data [20]. The discharge current is 40 mA

Рис. 6. Напряженность электрического поля в зависимости от давления; 1-  $N_2$ , 2 -  $O_2$ , 3 - Ar+2%  $N_2$ , 4 - Ar, 5 - воздух, 6, 7, 8 - в азоте, воздухе и аргоне соответственно по данным [20]. Ток 40 мА

#### ROTATIONAL, VIBRATIONAL AND GAS TEMPERATURES

Due to small discharge dimensions (Fig. 3) practically the only methods for discharge studies are emission spectroscopy [1], absorption spectroscopy [27], and laser induced fluorescence (LIF) [12]. The emission spectroscopy is exclusively used for determination of rotational and vibrational temperatures. The rotational temperatures are obtained from a distribution of emission intensities in vibrational bands of emission of excited states of second positive system  $N_2(C^3\Pi_u \rightarrow B^3\Pi_g)$ , usually (0-2) band is utilized.

Emission bands of OH are detected already in a discharge with water cathode and  $N_2$  exists as admixture or it is intentionally introduced into plasma-forming gas as a small addition ~0.1-0.2% [11, 13, 21]. Since the rotational constants of OH ( $A^2\Sigma$ ) and  $N_2(C^3\Pi_u)$  are essentially less than  $k \times T$  ( $k$  is the Boltzmann constant) (for  $A^2\Sigma$  – 17.4  $cm^{-1}$  or 25 K, for  $C^3\Pi_u$  – 1.8  $cm^{-1}$  or 2.6 K) and collision frequencies of molecules for atmospheric pressure are  $10^9 s^{-1}$  it is possible to assume that the rotational degrees of freedom are in equilibrium with the translational ones, i.e. the rotational temperature has to be equal to the gas temperature. All studies showed that for  $N_2(C^3\Pi_u)$  molecules, the distribution on rotational levels is the Boltzmann one with the same value of temperature [14, 15, 21, 26, 27-31]. At the same time, the distribution on rotational levels for OH ( $A^2\Sigma$ ,  $V=1$ ) can be described with the two Boltzmann distributions with different temperatures. Up to some rotational level,  $J'$ , which depend of plasma-forming gas kind ( $J'$  in-

creases from 13 up to 25 in series He, Ar, CO<sub>2</sub>, N<sub>2</sub>O, N<sub>2</sub>) the distribution is realized with the temperature which is equal to the one determined on the rotational temperature of N<sub>2</sub> molecules (see Table). For higher  $J'$  values, the temperature is significantly higher and it does not depend on the gas kind. At the same time, for the O<sub>2</sub> discharge the temperatures determined with both methods are the same [13]. When the irradiation is collected from the whole positive column, then the result is the temperature averaged on the reactor cross-section. Some results of such measurements are listed in Table.

Table.

**The results of rotational temperatures measurements at atmospheric pressure**

**Таблица. Результаты измерений вращательной температуры при атмосферном давлении**

| Gas (газ)        | T <sub>rot</sub> (OH), К | T <sub>rot</sub> (N <sub>2</sub> ), К | Current (ток), мА | References (литература) |
|------------------|--------------------------|---------------------------------------|-------------------|-------------------------|
| air (воздух)     | 3250±250                 | 3250±250                              | 25                | [21]                    |
| N <sub>2</sub>   | 3242±200                 | 2900±200                              | 25                | [21]                    |
| He               | 1282±200                 | 1100±200                              | 25                | [21]                    |
| Ar               | 2008±200                 | 2400±200                              | 25                | [21]                    |
| N <sub>2</sub> O | 2755±200                 | 2000±200                              | 25                | [21]                    |
| CO <sub>2</sub>  | 2931±200                 | 2100±200                              | 25                | [21]                    |
| air (воздух)     |                          | 1800±200                              | 20                | [26]                    |
| air (воздух)     | 2540                     | 1900±200                              | 31                | [30]                    |
| N <sub>2</sub>   | 3112±150                 |                                       | 31                | [14]                    |
| N <sub>2</sub>   | 1450±150                 |                                       | 40                | [12]                    |
| He               | 2218±150                 |                                       | 31                | [14]                    |
| Ar               | 1720±150                 |                                       | 31                | [14]                    |
| air (воздух)     | 3400±200                 | 1800±200                              | 23                | [15]                    |
| air (воздух)     |                          | 2000±1500                             | 10-40             | [16]                    |
| O <sub>2</sub>   | 2700±100                 | 2700±100                              | 40                | [13]                    |

The temperatures depend only slightly on the discharge current [15, 16] but significantly on the pressure [11-13]. Any essential dependence on the concentration of the dissolved substance (KCl, NaCl) is not observed [15, 16].

The distribution of N<sub>2</sub>(C<sup>3</sup>Π<sub>u</sub>) molecules on vibrational level (V = 0-4) was measured for atmospheric pressure plasma in air in studies [10, 15, 26, 24, 31]. It was found that the distribution is the Boltzmann one with the temperature of T<sub>v</sub>~(4200±200) K. The temperature did not depend on the discharge current in the range of 10-110 mA.

The distribution of NO(A<sup>2</sup>Σ, V = 0, 1, 2) molecules on vibrational levels was determined on the intensity of vibrational-rotational bands of γ-system for air plasma in study [26] at the discharge current of 20 mA. The temperature obtained was (3800±200) K, i.e. it was close to T<sub>v</sub> for N<sub>2</sub>(C<sup>3</sup>Π<sub>u</sub>) in a limit of error.

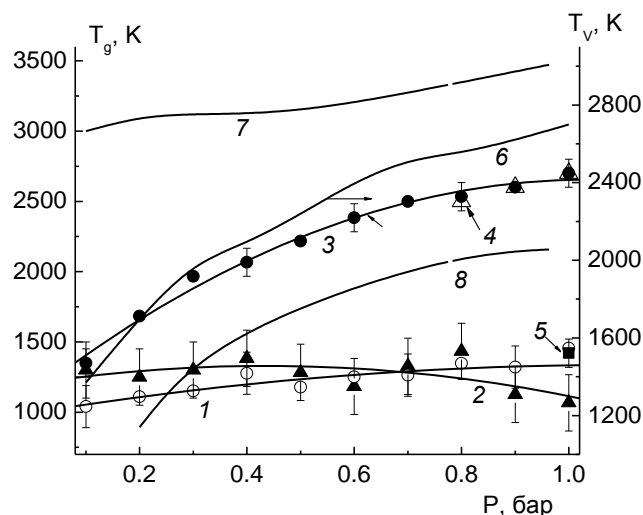

Fig. 7. Gas temperatures (T<sub>g</sub>) averaged over plasma cross-section and effective vibrational temperature (T<sub>v</sub>) of O<sub>2</sub>(X) as a function of pressure. 1 – Ar from study [11], 2 – N<sub>2</sub> from study [12], 3, 4, 7, 8 – O<sub>2</sub> [13], 5 - ambient air from study [16]. 1, 2, 3 were obtained on the rotational temperature of N<sub>2</sub>. 4 was obtained on the rotational temperature of OH. 6 - the T<sub>v</sub> calculation at averaged gas temperature [13], 7 – the temperature at discharge axis, T<sub>0</sub>, 8 – the temperature at discharge boarder, T<sub>R</sub>. The discharge current is 40 mA

Рис. 7. Средние по сечению плазмы температуры газа (T<sub>g</sub>) и эффективная колебательная температура O<sub>2</sub>(X) как функция давления. 1 - Ar [9], 2 - N<sub>2</sub> [12], 3, 4, 7, 8 - O<sub>2</sub> [13], 5 - воздух [16]. 1, 2, 3 - получено по вращательной температуре N<sub>2</sub>. 4 - получено по вращательной температуре OH. 6 - T<sub>v</sub> расчет с использованием средних температур [13]. 7 - температура газа на оси разряда, T<sub>0</sub>, 8 - температура газа на границе разряда, T<sub>R</sub>. Ток 40 мА

The distribution of OH(A<sup>2</sup>Σ, V = 0, 1, 2) molecules on vibrational levels was found on the intensity of vibrational-rotational bands of (A<sup>2</sup>Σ→X<sup>2</sup>Π) transitions for air plasma in studies [24, 26]. The temperature obtained in [26] was (3800±200) K at the discharge current of 20 mA. The T<sub>v</sub> values were increased from (2000±200) up to (3300±200) K at the discharge current increase from 15 up to 50 mA [24].

We do not know any experimental data on vibrational temperatures of ground state molecules of plasma-forming gases and products of their reactions. But there are several calculations carried out in studies [10, 31] for air plasma, in [11] for argon plasma, in [12] for N<sub>2</sub> plasma, and in [13] for O<sub>2</sub> plasma. In these studies, the self-consistent calculation of electron energy distribution functions (EEDF), molecule distributions on vibrational levels of ground states and equations of chemical kinetics was carried out. For discharges in Ar and O<sub>2</sub>, the small admixture of N<sub>2</sub>(<0.2%) molecules was introduced. The calculated T<sub>v</sub> was fitted to the measured one to find the water molecule content in a gas phase. In all cases the calculated distributions were non-equilibrium. But they

can be described by the Boltzmann distribution for low values of vibrational quantum number (Fig. 8, 9).

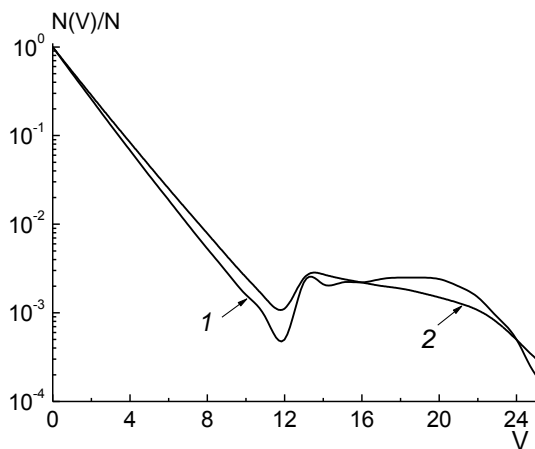

Fig. 8. The normalized distribution of  $N_2(X^1\Sigma_g^+)$  molecules on vibration levels for nitrogen plasma [12].  $V$  - number of level. 1 - 0.1 bar, 2 - 1.0 bar. The discharge current is 40 mA

Рис. 8. Нормированное распределение молекул  $N_2(X^1\Sigma_g^+)$  по колебательным уровням в плазме азота [12].  $V$  - номер колебательного уровня. 1 - 0,1 бар, 2 - 1,0 бар. Ток разряда 40 мА

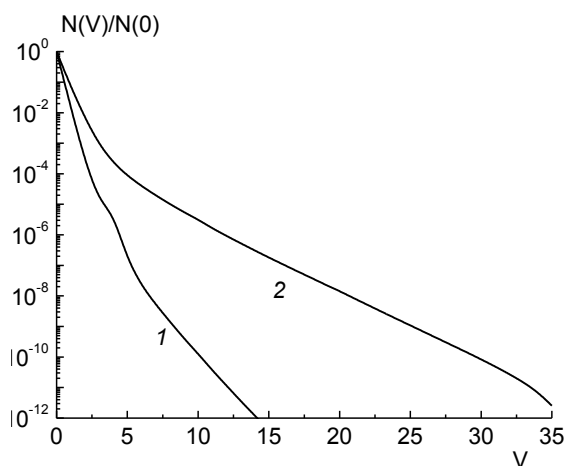

Fig. 9. The  $O_2(X^3\Sigma_g^-)$  molecule distribution on vibrational levels at the averaged gas temperature for oxygen plasma [13].  $V$  - number of vibration level. 1, 2 - pressures are 0.1 and 1.0 bar, respectively. The discharge current is 40 mA

Рис. 9. Распределение молекул  $O_2(X^3\Sigma_g^-)$  по колебательным уровням для плазмы кислорода [13].  $V$  - номер колебательного уровня. 1, 2 - давление 0,1 и 1,0 бар, соответственно. Ток разряда 40 мА

Calculated vibrational temperatures for  $N_2(X^1\Sigma_g^+)$  ground state practically agree with the measured ones for  $N_2(C^3\Pi_u)$ . Therefore, vibrational temperature found for  $N_2(C^3\Pi_u)$  are a good estimate of the vibrational temperature of the ground state. For atmospheric pressure in air, the vibrational temperatures do not depend both on the discharge current as for  $N_2(X^1\Sigma_g^+)$  and for ground states of other molecules. They were  $O_2(X^3\Sigma_g^-) \sim 1700$  K,  $H_2O(010)$

$\sim 3000$  K,  $H_2O(100,001) \sim 2700$  K,  $NO \sim 1600$  K [10]. At the given discharge current, the vibrational temperatures increase with pressure. Such dependence is presented in Fig. 7 [13] for current of 40 mA in oxygen whereas for Ar plasma - in Fig. 10 [11].

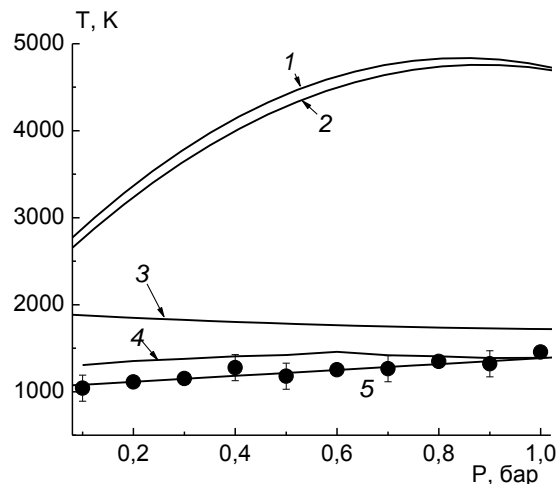

Fig. 10. The effective vibrational temperatures of molecules ground states for Ar plasma [11].  $H_2O(100)$ -(1),  $H_2O(001)$ -(2),  $O_2$ -(3),  $H_2O(010)$  - (4). The gas temperature - (5). The discharge current is 40 mA

Рис. 10. Колебательные температуры основных состояний молекул для плазмы Ar [11].  $H_2O(100)$ -(1),  $H_2O(001)$ -(2),  $O_2$ -(3),  $H_2O(010)$  - (4). Температура газа - (5). Ток разряда 40 мА

#### REDUCED ELECTRIC FIELD STRENGTH. ELECTRON PARAMETERS

In non-equilibrium plasma the initiation of all primary processes proceeds under the electron impact. To find the rate constants of these processes, it is necessary to know the EEDF which is non-equilibrium. For the conditions of high pressures the EEDF cannot be determined experimentally. The only possible way is the numerical solution of the Boltzmann equation. Parametrically, the EEDF is a function of reduced electric field strength,  $E/N$  ( $N$  is the total concentration of particles), and plasma chemical composition [32].  $E/N$  value is to some extent an analog of temperature for non-equilibrium EEDF.  $E/N$  is determined on the basis of  $E$  measurement and  $N$  is calculated on a pressure.  $T_g$  is calculated from state equation  $P = N \times k T_g$ .  $E/N$  values depend on pressure and discharge current (Figs. 11, 12).

The electron collisions with water molecules have the strongest effect on the EEDF formation. The reason for this is an abnormally high value of moment transfer cross section for electron collision with  $H_2O$  in comparison with other gases [33].  $H_2O$  molecules are affected most strongly at  $E/N < 5 \cdot 10^{-16}$  V·cm<sup>2</sup> [34,35]. These values are typical for atmospheric pressure gas discharges (Figs 11, 12).

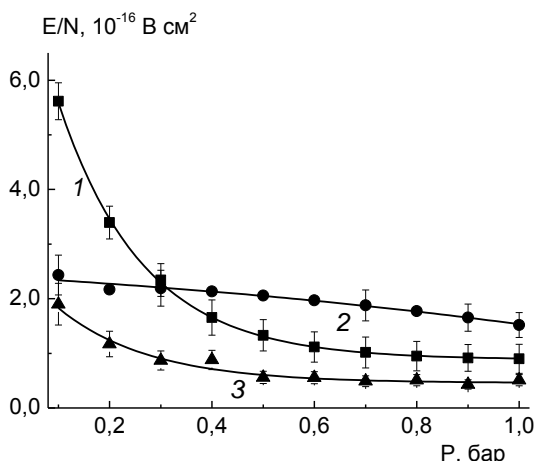

Fig. 11. The dependence of  $E/N$  on pressure. 1 –  $O_2$ , 2 –  $N_2$ , 3 – Ar [11-13]. The discharge current is 40 mA  
 Рис. 11. Зависимость  $E/N$  от давления. 1 –  $O_2$ , 2 –  $N_2$ , 3 – Ar [11-13]. Ток разряда 40 мА

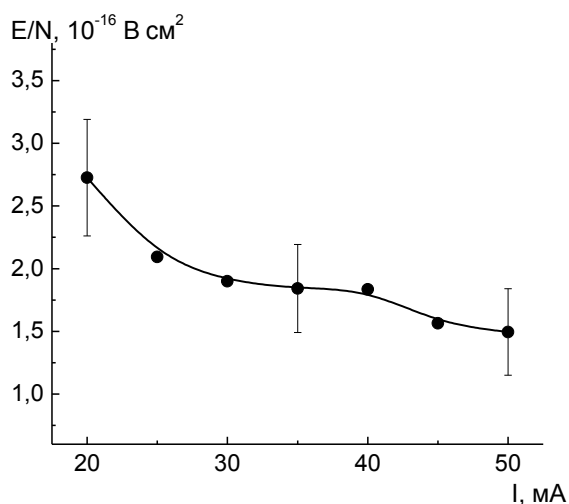

Fig. 12. The dependence of  $E/N$  on discharge current at atmospheric pressure for air plasma [17]  
 Рис. 12. Зависимость  $E/N$  от тока разряда при атмосферном давлении в плазме воздуха [17]

Such data for  $O_2$  plasma are presented in Fig. 13 [13]. Formation of other particles in plasma – excited molecules, atoms, and products of their reactions – influences the EEDF only slightly since their concentrations are less than 1% of main plasma-forming gas density. The exception is vibrationally excited nitrogen molecules in the ground state  $N_2(X^1\Sigma_g^+, V)$ . For air and nitrogen plasmas, it is obligatory to take into consideration the second-kind collisions of electrons with these molecules in EEDF calculations [10, 12]. If these processes are ignored it results in the strong underestimation (by orders of magnitude) of the rate constants of processes with the electron participation as it can be seen from Fig. 14. It is necessary to point out that all EEDF are not the Maxwell ones. Maxwell EEDF must be the straight lines for coordinates of Figs. 13, 14.

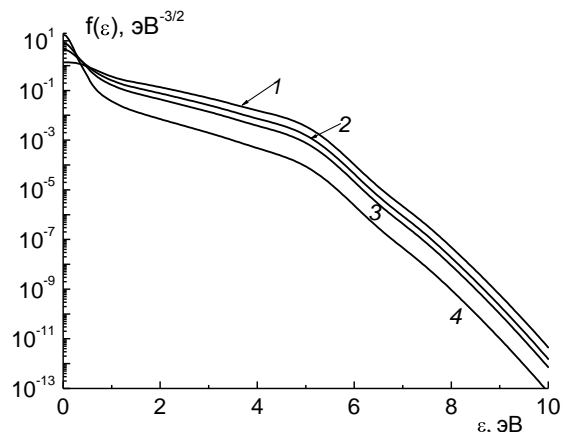

Fig. 13. Calculated electron energy distribution functions (EEDF) for  $O_2$  plasma at  $E/N = 1 \cdot 10^{-16}$  V/cm<sup>2</sup> (the pressure is 1 bar) and different content of water molecules [12]. 1, 2, 3, 4 – water molecules content is 0.3%, 5%, and 10%, respectively. The discharge current is 40 mA. The EEDF is normalized as  $\int_0^\infty f(\epsilon) \cdot \epsilon^{1/2} \cdot d\epsilon = 1$   
 Рис. 13. Рассчитанная ФРЭЭ для плазмы  $O_2$  при  $E/N = 1 \cdot 10^{-16}$  В/см<sup>2</sup> (давление 1 бар) для разных содержаний молекул воды [12]. 1, 2, 3, 4 – содержание  $H_2O$  0,3%, 5% и 10%, соответственно. Ток разряда 40 мА. Нормировка ФРЭЭ-  $\int_0^\infty f(\epsilon) \cdot \epsilon^{1/2} \cdot d\epsilon = 1$

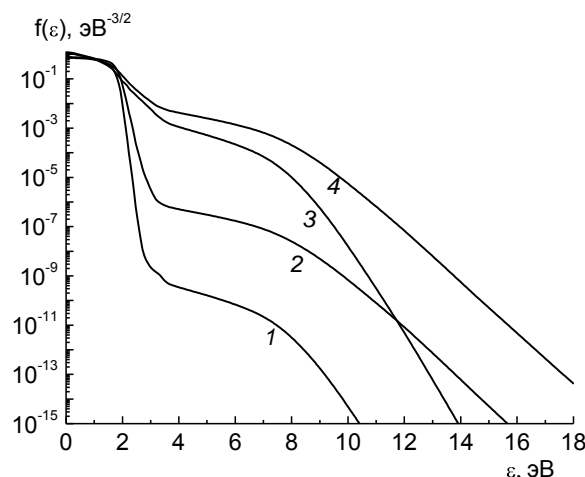

Fig. 14. Calculated EEDF for  $N_2$  plasma. 1,3 – at the pressure of 1 bar. 2,4 – at the pressure of 0.1 bar. 1,2 – second kind collisions with vibrationally excited  $N_2(X)$  did not take into account. 3,4 – second kind collisions with vibrationally excited  $N_2(X)$  were taken into account. The discharge current is 40 mA  
 Рис. 14. Рассчитанные ФРЭЭ для плазмы  $N_2$ . 1,3 – давление 1 бар. 2,4 – давление 0,1 бар. 1,2 – соударения 2-го рода не учитываются. 3,4 – соударения 2-го рода учтены

Another important parameter of electrons is the electron density, which is necessary for the calculation of process rates. Available data on concentrations were obtained either from experiments [19, 26, 28, 36, 37, 40] or from calculations using plasma conductivity [10-13, 16, 24, 38] by the relationship  $j = N_e \cdot e \cdot V_D$  ( $e$ ,  $N_e$ ,  $V_D$  are the charge, concentration and drift velocity of electrons, respectively).

In study [36] the electron density was measured for atmospheric pressure air plasma on absorption of microwave radiation at the discharge current of 40-60 mA. The electron density did not depend on the current and was found to be  $(4-7) \cdot 10^{12} \text{ cm}^{-3}$ . This value was confirmed with probes measurements [40].

Electron density was measured on Stark broadening of  $H_{\beta}$  line of atomic hydrogen for atmospheric pressure air discharges in studies [19, 26, 28, 37]. Furthermore, the slight dependence on discharge current was observed. The concentrations obtained in all studies were close: [19, 28] –  $\sim(5-9) \cdot 10^{14} \text{ cm}^{-3}$ , [24] –  $\sim 6 \cdot 10^{14} \text{ cm}^{-3}$ , [35] –  $\sim(1.5-4.5) \cdot 10^{14} \text{ cm}^{-3}$ .

In any case, the calculation of plasma conductivity gave the values by one order of magnitude lower. Thus, in study [10] for the atmospheric pressure air plasma it was obtained that the electron density increased with discharge current from  $1.5 \cdot 10^{12} \text{ cm}^{-3}$  to  $2.8 \cdot 10^{12} \text{ cm}^{-3}$  at current range of (20-50) mA. The value estimated in [38] gives  $N_e < 2 \cdot 10^{13} \text{ cm}^{-3}$ . In studies [11-13] the values of  $\sim 1 \cdot 10^{13} \text{ cm}^{-3}$ ,  $\sim 8 \cdot 10^{12} \text{ cm}^{-3}$  and  $\sim 1.1 \cdot 10^{13} \text{ cm}^{-3}$  were obtained for atmospheric pressure plasmas in Ar,  $N_2$  and  $O_2$ , respectively at discharge current of 40 mA.

To explain so large difference, the authors of review [1] write that photometric determination of the discharge radius, which is necessary for discharge current density calculation, results in large errors. But it is not completely true. Photometric determination can only underestimate the radius due to the insufficient sensitivity. Therefore, the calculation of conductivity has to result in concentration overstating rather than in understating. Later, in study [39] a detailed analysis of the methods based on Stark line broadening was carried out. On the basis of careful analysis authors concluded that at  $N_e < 1 \cdot 10^{14} \text{ cm}^{-3}$  the use of the relations connecting concentration and line width, which were obtained for  $N_e > 1 \cdot 10^{14} \text{ cm}^{-3}$  (see, for example, [41]) for  $N_e$  determination, results in large errors. It follows that the relationships obtained for  $N_e > 1 \cdot 10^{14} \text{ cm}^{-3}$  do not take in consideration the differences in average energies of electrons and ions, neither the fine structure of lines. The authors of all cited studies [19, 26, 28, 37] treated the results exactly so. Therefore, the data obtained from plasma conductivity appear more realistic. Some data on electron concentrations and their “effective” temperatures are also discussed in the review paper [47].

For the fixed discharge current the electron densities depend on a pressure and they grow with the pressure. Such dependencies for discharges in Ar,  $O_2$ , and  $N_2$  are shown in Fig. 15 [11-13].

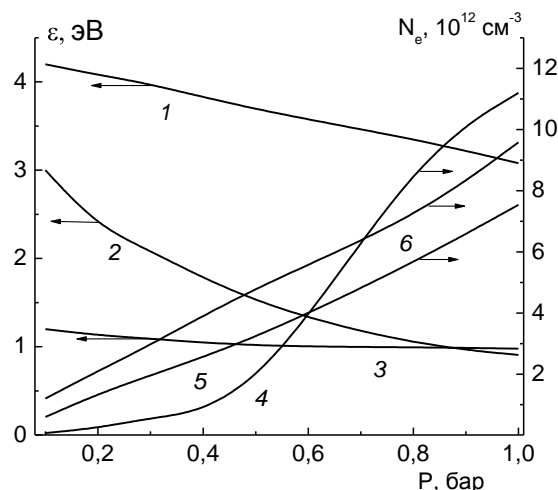

Fig. 15. Average electron energies (1-3) and their densities (4-6) vs pressure. 1,6 – Ar, 2,4 –  $O_2$ , 3,5 –  $N_2$ . The discharge current is 40 mA

Рис. 15. Средние энергии (1-3) и концентрации электронов (4-6) в зависимости от давления. 1,6 – Ar, 2,4 –  $O_2$ , 3,5 –  $N_2$ . Ток разряда 40 мА

Numerous studies are devoted to the determination of the so called effective temperatures of excitation and ionization. For this, the assumptions on Boltzmann distribution and ratio of intensities of appropriate lines or bands are used (see, for example, [19, 26, 42]). It is clear that such parameters do not have any physical sense for non-equilibrium systems. That is why we even avoid the discussion of these results. The estimation of electron “temperatures” and their average energy have also restricted application since EEDFs are not Maxwellian ones. Nevertheless, Fig. 15 shows some data obtained in [11-13] on the basis of the calculated EEDF.

#### PARTICLE COMPOSITION OF GAS PHASE

Qualitative data on composition are available for excited particles only. All data were obtained by optical spectroscopy. But it is known that for non-equilibrium conditions, the particle concentration in ground state is essentially higher than for excited states. Of course, it is impossible to determine the presence of metastable states as well as polyatomic molecules using emission spectra.

For any plasma-forming gases the spectra show the bands and emission lines of excited states of dissociation products of  $H_2O$  molecules [13, 14, 19]. OH radicals are usually presented with two bands of  $A^2\Sigma \rightarrow X^2\Pi$  (1-0) and  $A^2\Sigma \rightarrow X^2\Pi$  (0-0) (excitation energy from the ground states is  $\sim 4.1 \text{ eV}$ ). Atomic hydrogen shows three lines:  $H_{\alpha}$  (656 nm, excitation energy is  $\sim 12.1 \text{ эВ}$ ),  $H_{\gamma}$  (434 nm, excitation energy is  $\sim 13.1 \text{ eV}$ ), and  $H_{\beta}$  (486 nm, excitation energy is  $\sim 12.8 \text{ eV}$ ). The radiation of O(I) atom is presented with the two



most intensive lines – 777 nm ( $3p^5P \rightarrow 3s^5S$  transition, excitation energy is  $\sim 10.7$  eV) and 845 nm ( $3p^3P \rightarrow 3s^3S$  transition, excitation energy is  $\sim 10.9$  eV).

If plasma-forming gas contains molecular nitrogen, then in emission spectra the bands of second positive system ( $C^3\Pi_u \rightarrow B^3\Pi_g$  transition, excitation energy is  $\sim 11$  eV) corresponding to (1-2); (0-1); (2-4); (1-3); (0-2); (3-6); (2-5); (1-4); (0-3); (4-8), (3-7); (2-6) vibrational levels appear. The bands of the first positive system (transition  $B^3\Pi_g \rightarrow A^3\Sigma_u^+$ ) are also present but are essentially less intensive.

The emission bands of nitrogen oxide (NO) of  $\gamma$ -system (transition  $A^2\Sigma \rightarrow X^2\Pi$ , excitation energy of  $\sim 5.7$  eV) corresponding to (1-0), (2-2), (0-0), (0-1), (0-2), (0-3) and (0-4) transitions are also appeared.

The discharge in  $CO_2$  shows the emission bands of CO molecules of Angstrom system, and in Ar plasma the set of characteristic emission lines is appears. The exception is He plasma where the emission lines do not appear. This is due to the fact that the excitation energy of He electronic states is too large (19.8 eV and higher), whereas the electron energies at atmospheric pressure are low. As the result, the excitation rates of electronic states are low.

At the presence of salts dissolved in water, the emission lines (presumably for resonance transitions) of appropriate metal (Na, K, Ca, Cu, Cd, Zn, Ni, Pb, Cs, Mg) [16, 17, 26, 38, 43-44] show up. The emission has the threshold character, i.e. the appropriate lines appear at the definite value of discharge current.

It is necessary to point out that in spite of the fact that the appropriate metals are present in a solution as cations, the emission spectrum shows only the lines of neutral atoms. Any lines or bands of anions contained in the salt are not observed.

As for discharge of low pressure, the emission bands of  $O_2$  molecule are not registered. It is not surprising, since the potential curves of the excited states (with the exception of the two lowest) are shifted against the ground state so that their excitation with electron impact from ground state has to result in dissociation according to the Franck-Condon principle.

Experimental data have been obtained for OH radicals only at atmospheric pressure. In studies [14, 29, 46] these data were obtained by LIF method and in study [27] – by the wideband adsorption. It was discovered that for the current range of 10-30 mA, OH concentration almost does not depend on the discharge current and equals to  $\sim 5 \cdot 10^{13}$   $cm^{-3}$  for Ar plasma. For He and  $N_2$  plasmas the concentration growth is directly proportional to the current and changes from  $5 \cdot 10^{14}$  to  $1.4 \cdot 10^{15}$   $cm^{-3}$  for He and from  $2 \cdot 10^{15}$  to  $2.3 \cdot 10^{15}$   $cm^{-3}$  for  $N_2$  plasma. For air plasma

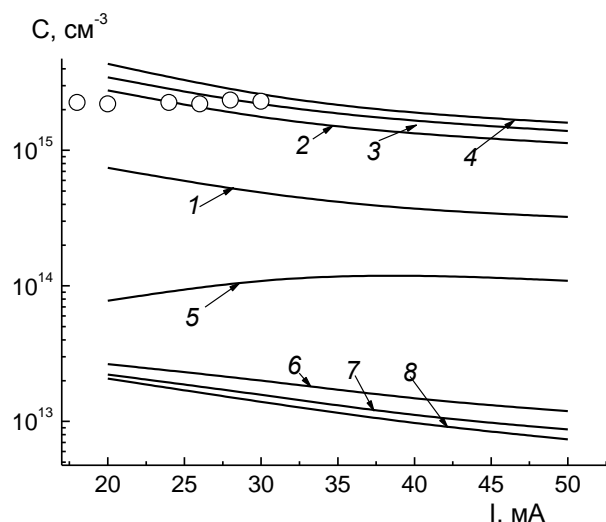

Fig. 16. The dependence of  $\bullet OH$  and  $HO_2\bullet$  radicals concentration on the discharge current. Water content is 1, 5 – 0.05%; 2, 6 – 2.3%; 3, 7 – 5%, 4, 8 – 10%, respectively.  $\bullet OH$  (1, 2, 3, 4),  $HO_2\bullet$  (5, 6, 7, 8). Points are experimental data of study [46]

Рис. 16. Зависимость концентрации радикалов  $\bullet OH$  и  $HO_2\bullet$  от тока разряда. Содержание паров воды 1, 5 – 0,05%; 2, 6 – 2,3%; 3, 7 – 5%, 4, 8 – 10% соответственно.  $\bullet OH$  (1, 2, 3, 4),  $HO_2\bullet$  (5, 6, 7, 8). Точки – экспериментальные данные работы [46]

[29, 46] in the same range of currents the concentration increases from  $1.3 \cdot 10^{15}$  up to  $1.8 \cdot 10^{16}$   $cm^{-3}$ . The radial distribution of OH concentration was measured for air plasma for the discharge current of 13 mA in study [27]. The concentration at the discharge axis was  $\sim 1.7 \cdot 10^{17}$   $cm^{-3}$ . Therefore, averaged on discharge cross-section concentration is  $\sim 8 \cdot 10^{16}$   $cm^{-3}$ . Concentrations of all other particles were obtained by numerical modeling. The most reliable data for atmospheric pressure air plasma are presented in study [10] in the discharge current range of (20-40) mA. For Ar,  $N_2$  and  $O_2$  plasmas the similar results were obtained in the pressure range of (0.1-1) bar and at the discharge current of 40 mA [11-13]. These articles are the only ones, where the self-consistent approach was used for modeling. The Boltzmann equation for the electrons, equations of vibrational kinetics, equation of plasma conductivity, and equations of chemical kinetics including excited states were jointly solved. The reduced electric field strengths, gas and vibrational temperatures for  $N_2(C^3\Pi_u)$ , intensities of bands and lines were measured experimentally. Intensities of bands and lines and vibrational temperatures were used for determination of water content. For vibrational kinetics, the pumping of vibrational states (for air it were  $N_2$ ,  $O_2$ , NO,  $H_2O$ ) with electron impact as well as V-V and V-T single quantum exchange were taken into consideration. The rate constants of these processes were calculated by the generalized SSH theory without any approximations [48]. Some chem-

ical reactions were taken into account as well. For air the process list included 187 reactions with the participation of the excited and ground states for the following molecules and atoms: N<sub>2</sub>, O<sub>2</sub>, H<sub>2</sub>O, H<sub>2</sub>O<sub>2</sub>, N, NO, N<sub>2</sub>O, NO<sub>2</sub>, NO<sub>3</sub>, HNO<sub>2</sub>, HNO<sub>3</sub>, O, OH, HO<sub>2</sub>, H, H<sub>2</sub>, O<sub>3</sub>, O<sub>2</sub><sup>+</sup>, O<sup>+</sup>, O<sub>2</sub><sup>-</sup>, O<sup>-</sup> and the electrons.

Calculations showed that in plasma of such discharge the substantial amount of nitrogen oxides with the different oxidation level are formed (NO~10<sup>16</sup> cm<sup>-3</sup>, NO<sub>2</sub>~6·10<sup>14</sup> cm<sup>-3</sup>, N<sub>2</sub>O~2·10<sup>14</sup> cm<sup>-3</sup>). Along with nitrogen oxide molecules the nitric acid (HNO<sub>3</sub>~10<sup>15</sup> cm<sup>-3</sup>), nitrous acid (HNO<sub>2</sub>~4·10<sup>13</sup> cm<sup>-3</sup>), and nitroxyl molecules (HNO ~6·10<sup>14</sup> cm<sup>-3</sup>) are formed. The main oxygen-hydrogen containing particles were ·OH, HO<sub>2</sub> radicals (Fig. 16) and hydrogen

peroxide (~10<sup>15</sup> cm<sup>-3</sup>). The interesting feature of this discharge is low concentration of ozone (<10<sup>11</sup> cm<sup>-3</sup>) even in the case of oxygen plasma.

The concentrations of atomic oxygen O(<sup>3</sup>P) and O<sub>2</sub>(a<sup>1</sup>Δ<sub>g</sub>) and O<sub>2</sub>(b<sup>1</sup>Σ<sub>g</sub><sup>+</sup>) metastable states were ~10<sup>15</sup> cm<sup>-3</sup>.

Therefore, the discharges of higher pressure with liquid cathode provide a wide set of active species possessing high redox properties.

#### Acknowledgements

*This study was supported by the RFBR grant, project number 14-02-01113 A. Part of this work was supported by Ministry of Education and Science of the Russian Federation (the project N 4.1385.2014/K).*

#### ЛИТЕРАТУРА

1. **Bruggeman P., Leys C.** Non-thermal plasmas in and in contact with liquids. *J. Phys. D: Appl. Phys.* 2009. V. 42. N 5. P. 053001.
2. **Tatarova E., Bundaleska N., Sarrette L.Ph., Ferreira C.M.** Plasmas for environmental issues: from hydrogen production to 2D materials assembly. *Plasma Sources Sci. Technol.* 2014. V. 23. N 6. P. 063002.
3. **Jiang B., Zheng J., Qiu S., Wu M., Zhang Q., Yan Z., Xue Q.** Review on electrical discharge plasma technology for wastewater remediation. *Chem. Ing. J.* 2014. V. 236. P. 348.
4. **Locke B.R., Mededovic Thagard S.M.** Analysis and Review of Chemical Reactions and Transport Processes in Pulsed Electrical Discharge Plasma Formed Directly in Liquid Water. *Plasma Chem. Plasma Process.* 2012. V. 32. N 5. P. 875.
5. **Бобкова Е.С., Гриневич В.И., Исакина А.А., Рыбкин В.В.** Разложение органических соединений в водных растворах под действием электрических разрядов атмосферного давления. *Изв. вузов. Химия и хим. технология.* 2011. Т. 54. Вып. 6. С. 3-17.
6. **Fridman A.** Plasma Chemistry. Cambridge University Press. 2008. 978 p.
7. **Choi H.S., Shikova T.G., Titov V.A., Rybkin V.V.** Surface oxidation of polyethylene using an atmospheric pressure glow discharge with liquid electrolyte cathode. *J. Colloid. Interface Sci.* 2006. V. 300. N 2. P. 640.
8. **Misra N.N.** The contribution of non-thermal and advanced oxidation technologies towards dissipation of pesticide residues. *Trends Food Sci. Technol.* 2015. V. 45. N 2. P. 229.
9. **Mu R., Liu Y., Li R., Xue G., Ognier S.** Remediation of pyrene-contaminated soil by active species generated from flat-plate dielectric barrier discharge. *Chem. Ing. J.* 2016. DOI: 10.1016/j.cej.2016.03.106.
10. **Bobkova E., Smirnov S., Zalipaeva Yu., Rybkin V.** Modeling Chemical Composition for an Atmospheric Pressure DC Discharge in Air with Water Cathode by 0-D model. *Plasma Chem. Plasma Process.* 2014. V. 34. N 4. P. 721.
11. **Shutov D., Smirnov S., Bobkova E., Rybkin V.** Ionization Mechanism and Chemical Composition of an Argon DC Discharge with Water Cathode. *Plasma Chem. Plasma Process.* 2015. V. 35. N 1. P. 107.

#### REFERENCES

1. **Bruggeman P., Leys C.** Non-thermal plasmas in and in contact with liquids. *J. Phys. D: Appl. Phys.* 2009. V. 42. N 5. P. 053001. DOI: 10.1088/0022-3727/42/5/053001.
2. **Tatarova E., Bundaleska N., Sarrette L.Ph., Ferreira C.M.** Plasmas for environmental issues: from hydrogen production to 2D materials assembly. *Plasma Sources Sci. Technol.* 2014. V. 23. N 6. P. 063002. DOI: 10.1088/0963-0252/23/6/063002.
3. **Jiang B., Zheng J., Qiu S., Wu M., Zhang Q., Yan Z., Xue Q.** Review on electrical discharge plasma technology for wastewater remediation. *Chem. Ing. J.* 2014. V. 236. P. 348. DOI: 10.1016/j.cej.2013.09.090.
4. **Locke B.R., Mededovic Thagard S.M.** Analysis and Review of Chemical Reactions and Transport Processes in Pulsed Electrical Discharge Plasma Formed Directly in Liquid Water. *Plasma Chem. Plasma Process.* 2012. V. 32. N 5. P. 875.
5. **Bobkova E.S., Grinevich V.I., Isakina A.A., Rybkin V.V.** Decomposition of organic substances in aqueous solutions under action of electric discharges of atmospheric pressure. *Izv. Vyssh. Uchebn. Zaved. Khim. Khim. Tekhnol.* 2011. V. 54. N 6. P. 3-17 (in Russian).
6. **Fridman A.** Plasma Chemistry. Cambridge University Press. 2008. 978 p.
7. **Choi H.S., Shikova T.G., Titov V.A., Rybkin V.V.** Surface oxidation of polyethylene using an atmospheric pressure glow discharge with liquid electrolyte cathode. *J. Colloid. Interface Sci.* 2006. V. 300. N 2. P. 640.
8. **Misra N.N.** The contribution of non-thermal and advanced oxidation technologies towards dissipation of pesticide residues. *Trends Food Sci. Technol.* 2015. V. 45. N 2. P. 229.
9. **Mu R., Liu Y., Li R., Xue G., Ognier S.** Remediation of pyrene-contaminated soil by active species generated from flat-plate dielectric barrier discharge. *Chem. Ing. J.* 2016. DOI: 10.1016/j.cej.2016.03.106.
10. **Bobkova E., Smirnov S., Zalipaeva Yu., Rybkin V.** Modeling Chemical Composition for an Atmospheric Pressure DC Discharge in Air with Water Cathode by 0-D model. *Plasma Chem. Plasma Process.* 2014. V. 34. N 4. P. 721.
11. **Shutov D., Smirnov S., Bobkova E., Rybkin V.** Ionization Mechanism and Chemical Composition of an Argon DC Discharge with Water Cathode. *Plasma Chem. Plasma Process.* 2015. V. 35. N 1. P. 107.

12. **Smirnov S., Shutov D., Bobkova E., Rybkin V.** Physical Parameters and Chemical Composition of a Nitrogen DC Discharge with Water Cathode. *Plasma Chem. Plasma Process.* 2015. V. 35. N 4. P. 639.
13. **Smirnov S., Shutov D., Bobkova E., Rybkin V.** Chemical Composition, Physical Properties and Populating Mechanism of Some O(I) States for a DC Discharge in Oxygen with Water Cathode. *Plasma Chem. Plasma Process.* 2016. V. 36. N 2. P. 415.
14. **Li L., Nikiforov A., Xiong Q., Lu X., Taghizadeh L., Leys C.** Measurement of OH radicals at state X 2Π in an atmospheric-pressure micro-flow dc plasma with liquid electrodes in He, Ar and N<sub>2</sub> by means of laser-induced fluorescence spectroscopy. *J. Phys. D: Appl. Phys.* 2012. V. 45. N 12. P. 125201.
15. **Bruggeman P., Liu J.J., Degroote J., Kong M.G., Vierendeels J., Leys C.** DC excited glow discharges in atmospheric pressure air in pin-to-water electrode systems. *J. Phys. D: Appl. Phys.* 2008. V. 41. N 7. P. 215201.
16. **Titov V.A., Rybkin V.V., Maximov A.I., Choi H.S.** Characteristics of atmospheric pressure glow discharge with aqueous electrolyte cathode. *Plasma Chem. Plasma Process.* 2005. V. 25. N 5. P. 503.
17. **Cserfalvi T., Mezei P.** Operating mechanism of the electrolyte cathode atmospheric glow discharge. *Fresenius J. Anal. Chem.* 1996. V. 355. N 7-8. P. 813.
18. **Gaisin A.R., Son E.E.** Vapor air discharges between electrolytic cathode and metal anode at atmospheric pressure. *High Temperature.* 2005. V. 43. N 1. P. 1.
19. **Bruggeman P., Rubezl E., Maslani A., Degroote J., Malesevich A., Rego R., Vierendeels J., Leys C.** Characteristics of atmospheric pressure air discharges with a liquid cathode and a metal anode. *Plasma Sources Sci. Technol.* 2008. V. 17. N 2. P. 025012.
20. **Бобкова Е.С., Шикова Т.Г., Гриневиц В.И., Рыбкин В.В.** Анализ механизма образования пероксида водорода в разряде постоянного тока атмосферного давления с электролитным катодом. *Химия высоких энергий.* 2012. Т. 46. № 1. С. 60.
21. **Verreysken T., Schram D.C., Leys C., Bruggeman P.** Spectroscopic study of an atmospheric dc glow discharge with a water electrode in atomic and molecular gases. *Plasma Sources Sci. Technol.* 2010. V. 19. N 4. P. 045004.
22. **Mezei P., Cserfalvi T.** The investigation of an abnormal electrolyte cathode atmospheric glow discharge (ELCAD). *J. Phys. D: Appl. Phys.* 2006. V. 39. N 12. P. 2534.
23. **Lu X.P., Laroussi M.** Atmospheric pressure glow discharge in air using a water electrode. *IEEE Trans. Plasma Sci.* 2005. V. 33. P. 272.
24. **Titov V.A., Rybkin V.V., Smirnov S.A., Kulentsan A.N., Choi H.S.** Experimental and theoretical studies on the characteristics of atmospheric pressure glow discharge with liquid cathode. *Plasma Chem. Plasma Process.* 2006. V. 26. N 6. P. 543.
25. **Коновалов А.С., Голубев С.Н., Иванов А.Н., Шутков Д.А., Смирнов С.А., Рыбкин В.В.** Электрофизические параметры тлеющего разряда с жидким электродом в атмосфере воздуха при пониженном давлении. *Иzv. вузов. Химия и хим. технология.* 2012. Т. 55. Вып. 12. С. 55.
26. **Jamrôz P., Zyrnicki W.** Spectroscopic Characterization of Miniaturized Atmospheric-Pressure dc Glow Discharge Generated in Contact with Flowing Small Size Liquid Cathode. *Plasma Chem. Plasma Process.* 2011. V. 31. N 5. P. 681.
12. **Smirnov S., Shutov D., Bobkova E., Rybkin V.** Physical Parameters and Chemical Composition of a Nitrogen DC Discharge with Water Cathode. *Plasma Chem. Plasma Process.* 2015. V. 35. N 4. P. 639. DOI: 10.1007/s11090-015-9596-3.
13. **Smirnov S., Shutov D., Bobkova E., Rybkin V.** Chemical Composition, Physical Properties and Populating Mechanism of Some O(I) States for a DC Discharge in Oxygen with Water Cathode. *Plasma Chem. Plasma Process.* 2016. V. 36. N 2. P. 415.
14. **Li L., Nikiforov A., Xiong Q., Lu X., Taghizadeh L., Leys C.** Measurement of OH radicals at state X 2Π in an atmospheric-pressure micro-flow dc plasma with liquid electrodes in He, Ar and N<sub>2</sub> by means of laser-induced fluorescence spectroscopy. *J. Phys. D: Appl. Phys.* 2012. V. 45. N 12. P. 125201.
15. **Bruggeman P., Liu J.J., Degroote J., Kong M.G., Vierendeels J., Leys C.** DC excited glow discharges in atmospheric pressure air in pin-to-water electrode systems. *J. Phys. D: Appl. Phys.* 2008. V. 41. N 7. P. 215201.
16. **Titov V.A., Rybkin V.V., Maximov A.I., Choi H.S.** Characteristics of atmospheric pressure glow discharge with aqueous electrolyte cathode. *Plasma Chem. Plasma Process.* 2005. V. 25. N 5. P. 503.
17. **Cserfalvi T., Mezei P.** Operating mechanism of the electrolyte cathode atmospheric glow discharge. *Fresenius J. Anal. Chem.* 1996. V. 355. N 7-8. P. 813.
18. **Gaisin A.R., Son E.E.** Vapor air discharges between electrolytic cathode and metal anode at atmospheric pressure. *High Temperature.* 2005. V. 43. N 1. P. 1.
19. **Bruggeman P., Rubezl E., Maslani A., Degroote J., Malesevich A., Rego R., Vierendeels J., Leys C.** Characteristics of atmospheric pressure air discharges with a liquid cathode and a metal anode. *Plasma Sources Sci. Technol.* 2008. V. 17. N 2. P. 025012.
20. **Bobkova E.S., Shikova T.G., Grinevich V.I., Rybkin V.V.** Mechanism of hydrogen peroxide formation in electrolytic-cathode atmospheric-pressure direct-current discharge. *High Energy Chemistry.* 2012. V. 46. N 1. P. 56.
21. **Verreysken T., Schram D.C., Leys C., Bruggeman P.** Spectroscopic study of an atmospheric dc glow discharge with a water electrode in atomic and molecular gases. *Plasma Sources Sci. Technol.* 2010. V. 19. N 4. P. 045004.
22. **Mezei P., Cserfalvi T.** The investigation of an abnormal electrolyte cathode atmospheric glow discharge (ELCAD). *J. Phys. D: Appl. Phys.* 2006. V. 39. N 12. P. 2534.
23. **Lu X.P., Laroussi M.** Atmospheric pressure glow discharge in air using a water electrode. *IEEE Trans. Plasma Sci.* 2005. V. 33. P. 272.
24. **Titov V.A., Rybkin V.V., Smirnov S.A., Kulentsan A.N., Choi H.S.** Experimental and theoretical studies on the characteristics of atmospheric pressure glow discharge with liquid cathode. *Plasma Chem. Plasma Process.* 2006. V. 26. N 6. P. 543.
25. **Konovalev A.S., Golubev S.N., Ivanov A.N., Shutov D.A., Smirnov S.A., Rybkin V.V.** Electro-physical parameters of glow discharge with liquid electrode in air medium at lower pressure. *Izv. Vyssh. Uchebn. Zaved. Khim. Khim. Tekhnol.* 2012. V. 55. N 12. P. 55 (in Russian).
26. **Jamrôz P., Zyrnicki W.** Spectroscopic Characterization of Miniaturized Atmospheric-Pressure dc Glow Discharge Generated in Contact with Flowing Small Size Liquid Cathode. *Plasma Chem. Plasma Process.* 2011. V. 31. N 5. P. 681.

27. **Xiong Q., Yang Z., Bruggeman P.J.** Absolute OH density measurements in an atmospheric pressure dc glow discharge in air with water electrode by broadband UV absorption spectroscopy. *J. Phys. D: Appl. Phys.* 2015. V. 48. N 9. P. 424008. DOI: 10.1088/0022-3727/48/42/424008.
28. **Webb M.R., Andrade F.J., Gamez G., McCrindle R., Hieftje G.H.** Spectroscopic characterization of ion and electron populations in a solution-cathode glow discharge. *J. Anal. At. Spectrom.* 2005. V. 20. N 11. P. 1218.
29. **Nikiforov A., Xiong Q., Britun N., Snyders R., Lu X.P., Leys C.** Absolute Concentration of OH Radicals in Atmospheric Pressure Glow Discharges with a Liquid Electrode Measured by Laser-Induced Fluorescence Spectroscopy. *Appl. Phys. Express.* 2011. V. 4. N 2. P. 026102.
30. **Bruggeman P., Schram D., Gonzalez M.A., Rego R., Kong M.G., Leys C.** Characterization of a direct dc-excited discharge in water by optical emission spectroscopy. *Plasma Sources Sci. Technol.* 2009. V. 18. N 2. P. 025017.
31. **Рыбкин В.В., Смирнов С.А., Титов В.А., Аржаков Д.А.** Характеристики электронов и колебательных распределений молекул в разряде постоянного тока атмосферного давления в воздухе с жидким катодом. *Теплофизика высоких температур.* 2010. Т. 48. № 4. С. 498.
32. **Гинзбург В.Л., Гуревич А.В.** Нелинейные явления в плазме, находящейся в переменном электромагнитном поле. *УФН.* 1960. Т. LXX. № 2. С. 201.
33. **Рыбкин В.В., Титов В.А., Холодков И.В.** Кинетические характеристики и сечения взаимодействия электронов с молекулами воды. *Изв. вузов. Химия и хим. технология.* 2008. Т. 51. Вып. 3. С. 3.
34. **Бобкова Е.С., Рыбкин В.В.** Оценка параметров электронов в диэлектрическом барьерном разряде атмосферного давления в воздухе с жидким электродом. *Теплофизика Высоких Температур.* 2013. Т. 51. № 6. С. 825.
35. **Коновалов А.С., Рыбкин В.В., Смирнов С.А.** Влияние молекул воды на параметры электронов в неравновесной плазме воздуха. *Изв. вузов. Химия и хим. технология.* 2013. Т. 56. Вып. 11. С. 44.
36. **Barinov Y.A., Skol'nik S.M.** Probe measurements in a discharge with liquid nonmetallic electrodes in air at atmospheric pressure. *Tech. Phys.* 2002. V. 47. N 3. P. 313.
37. **Chen Q., Sato K., Takemura Y., Shirai H.** Physicochemistry of the plasma-electrolyte solution interface. *Thin Solid Films.* 2008. V. V. 516. N 19. P. 6688.
38. **Mezei P., Cserfaly T., Janossy M.** The gas temperature in the cathode surface - dark space boundary layer of an electrolyte cathode atmospheric glow discharge (ELCAD). *J. Phys. D: Appl. Phys.* 1998. V. 31. N 4. L. 14.
39. **Nikiforov A.Yu., Leys Ch., Gonzalez M.A., Walsh J.L.** Electron density measurement in atmospheric pressure plasma jets: Stark broadening of hydrogenated and non-hydrogenated lines. *Plasma Sources Sci. Technol.* 2015. V. 24. N 3. P. 034001.
40. **Баринов Ю.А., Школьник С.М.** Зондовые измерения в разряде с жидкими неметаллическими электродами в воздухе при атмосферном давлении. *Журн. техн. физики.* 2002. Т. 72. № 3. С. 31.
41. **Gigososa M.A., Gonzaez M.A., Cardenoso V.** Computer simulated Balmer-alpha, -beta and -gamma Stark line profiles for non-equilibrium plasmas diagnostics. *Spectrochim Acta B.* 2003. V. 58. N 8. P. 1489.
42. **Mezei P., Cserfalvi T., Csillag L.** The spatial distribution of the temperatures and the emitted spectrum in the electrolyte cathode atmospheric glow discharge. *J. Phys. D: Appl. Phys.* 2005. V. 38. N 16. P. 2804.
27. **Xiong Q., Yang Z., Bruggeman P.J.** Absolute OH density measurements in an atmospheric pressure dc glow discharge in air with water electrode by broadband UV absorption spectroscopy. *J. Phys. D: Appl. Phys.* 2015. V. 48. N 9. P. 424008. DOI: 10.1088/0022-3727/48/42/424008.
28. **Webb M.R., Andrade F.J., Gamez G., McCrindle R., Hieftje G.H.** Spectroscopic characterization of ion and electron populations in a solution-cathode glow discharge. *J. Anal. At. Spectrom.* 2005. V. 20. N 11. P. 1218.
29. **Nikiforov A., Xiong Q., Britun N., Snyders R., Lu X.P., Leys C.** Absolute Concentration of OH Radicals in Atmospheric Pressure Glow Discharges with a Liquid Electrode Measured by Laser-Induced Fluorescence Spectroscopy. *Appl. Phys. Express.* 2011. V. 4. N 2. P. 026102.
30. **Bruggeman P., Schram D., Gonzalez M.A., Rego R., Kong M.G., Leys C.** Characterization of a direct dc-excited discharge in water by optical emission spectroscopy. *Plasma Sources Sci. Technol.* 2009. V. 18. N 2. P. 025017.
31. **Rybkin V.V., Smirnov S.A., Titov V.A., Arzhakov D.A.** The characteristics of electrons and vibrational distributions of molecules in an atmospheric-pressure liquid-cathode DC discharge in air. *High Temperature.* 2010. V. 48. N 4. P. 476.
32. **Ginzburg V.L., Gurevich A.V.** Non-linear phenomena in a plasma in alternative electro-magnetic field. *UFN.* 1960. V. LXX. N 2. P. 201 (in Russian).
33. **Rybkin V.V., Titov V.A., Kholodkov I.V.** Kinetic parameters and cross-sections of interaction of electrons with water molecules. *Izv Vyssh Uchebn Zaved Khim Khim Tekhnol.* 2008. V. 51. N 3. P. 3 (in Russian).
34. **Bobkova E.S., Rybkin V.V.** Estimation of electron parameters in the dielectric barrier discharge with a liquid electrode at atmospheric pressure. *High Temperature.* 2013. V. 51. N 6. P. 747.
35. **Konovalev A.S., Rybkin V.V., Smirnov S.A.** Influence of water molecules on electron parameters in non-equilibrium air plasma. *Izv Vyssh Uchebn Zaved Khim Khim Tekhnol.* 2013. V. 56. N 11. P. 44 (in Russian).
36. **Barinov Y.A., Skol'nik S.M.** Probe measurements in a discharge with liquid nonmetallic electrodes in air at atmospheric pressure. *Tech. Phys.* 2002. V. 47. N 3. P. 313.
37. **Chen Q., Sato K., Takemura Y., Shirai H.** Physicochemistry of the plasma-electrolyte solution interface. *Thin Solid Films.* 2008. V. V. 516. N 19. P. 6688.
38. **Mezei P., Cserfaly T., Janossy M.** The gas temperature in the cathode surface - dark space boundary layer of an electrolyte cathode atmospheric glow discharge (ELCAD). *J. Phys. D: Appl. Phys.* 1998. V. 31. N 4. L. 14.
39. **Nikiforov A.Yu., Leys Ch., Gonzalez M.A., Walsh J.L.** Electron density measurement in atmospheric pressure plasma jets: Stark broadening of hydrogenated and non-hydrogenated lines. *Plasma Sources Sci. Technol.* 2015. V. 24. N 3. P. 034001.
40. **Barinov Yu.A., Shkol'nik S.M.** *Zhurn. Tekh. Fiziki.* 2002. V. 72. N 3. P. 31 (in Russian).
41. **Gigososa M.A., Gonzaez M.A., Cardenoso V.** Computer simulated Balmer-alpha, -beta and -gamma Stark line profiles for non-equilibrium plasmas diagnostics. *Spectrochim Acta B.* 2003. V. 58. N 8. P. 1489. DOI: 10.1016/S0584-8547(03)00097-1.
42. **Mezei P., Cserfalvi T., Csillag L.** The spatial distribution of the temperatures and the emitted spectrum in the electrolyte cathode atmospheric glow discharge. *J. Phys. D: Appl. Phys.* 2005. V. 38. N 16. P. 2804. DOI: 10.1088/0022-3727/38/16/010.

43. **Максимов А.И., Титов В.А., Хлюстова А.В.** Излучение тлеющего разряда с электролитным катодом и процессы переноса нейтральных и заряженных частиц из раствора в плазму. *Химия высоких энергий*. 2004. Т. 38. № 3. С. 227.
44. **Cserfalvi T., Mezei P., Apai P.** Emission studies on a glow discharge in atmospheric pressure air using water as a cathode. *J. Phys. D: Appl. Phys.* 1993. N 26. P. 2184.
45. **Mezei P., Cserfalvi T., Kim H.J., Mohammad A., Mottaleb M.A.** The influence of chlorine on the intensity of metal atomic lines emitted by an electrolyte cathode atmospheric glow discharge. *Analyst*. 2001. V. 126. N 5. P. 712.
46. **Nikiforov A.** Measurement of OH radicals density in plasma of DC discharge above electrolyte by means of laser-induced fluorescence spectroscopy. Proceedings of the VI International Symposium on Theoretical and Applied Plasma Chemistry. Russia. Ivanovo, 3-9 Sept. 2011. Ivanovo: ISUCT. 2011. P. 318.
47. **Mezei P., Cserfalvi T.** A Critical Review of Published Data on the Gas Temperature and the Electron Density in the Electrolyte Cathode Atmospheric Glow Discharges. *Sensors*. 2012. V. 12. N 5. P. 6576.
48. **Bobkova E.S., Rybkin V.V.** Analysis of Applicability of Translational Factor Approximations to Calculation of Vibrational Exchange Rate Constants in the  $N_2-O_2$  System under Low Pressure Discharge Conditions. *High Energy Chemistry*. 2016. V. 50. N 2. P. 139.
43. **Maksimov A.I., Titov V.A., Khlyustova A.V.** Electrolyte-as-Cathode Glow Discharge Emission and the Processes of Solution-to-Plasma Transport of Neutral and Charged Species. *High Energy Chemistry*. 2004. V. 38. N 3. P. 196.
44. **Cserfalvi T., Mezei P., Apai P.** Emission studies on a glow discharge in atmospheric pressure air using water as a cathode. *J. Phys. D: Appl. Phys.* 1993. N 26. P. 2184.
45. **Mezei P., Cserfalvi T., Kim H.J., Mohammad A., Mottaleb M.A.** *Analyst*. 2001. V. 126. N 5. P. 712. DOI: 10.1039/b010057i.
46. **Nikiforov A.** Measurement of OH radicals density in plasma of DC discharge above electrolyte by means of laser-induced fluorescence spectroscopy. Proceedings of the VI International Symposium on Theoretical and Applied Plasma Chemistry. Russia. Ivanovo, 3-9 Sept. 2011. Ivanovo: ISUCT. 2011. P. 318.
47. **Mezei P., Cserfalvi T.** A Critical Review of Published Data on the Gas Temperature and the Electron Density in the Electrolyte Cathode Atmospheric Glow Discharges. *Sensors*. 2012. V. 12. N 5. P. 6576.
48. **Bobkova E.S., Rybkin V.V.** Analysis of Applicability of Translational Factor Approximations to Calculation of Vibrational Exchange Rate Constants in the  $N_2-O_2$  System under Low Pressure Discharge Conditions. *High Energy Chemistry*. 2016. V. 50. N 2. P. 139.

*Поступила в редакцию 23.09.2016*

*Принята к опубликованию 18.11.2016*

*Received 23.09.2016*

*Accepted 18.11.2016*