

МЕХАНИЗМЫ УЛАВЛИВАНИЯ МЕЛКОДИСПЕРСНОЙ ПЫЛИ ВО ВЛАЖНОМ ПЫЛЕУЛОВИТЕЛЕ

Я. Кравчик, К. Кочевяк, Я. Талага, И. Постникова

Януш Кравчик, Катажина Кочевяк, Ян Талага

Кафедра промышленного оборудования, Институт теплотехники и технологии, Краковский технологический университет, пр. Яна Павла II, 37, Краков, 31-864, Польша

E-mail: jkrawczyk@pk.edu.pl

Ирина Постникова

Ивановский государственный химико-технологический университет, Шереметевский просп., 7, Иваново, Российская Федерация, 153000

E-mail: poirvic@mail.ru

Высокая эффективность интенсивной работы мокрых скрубберов является результатом одновременного образования различных механизмов пылеулавливания. Под коллекторами (пылеуловителями) можно понимать капли распыленной жидкости, пузырьки, образующиеся в условиях интенсивного барботирования, жидкую поверхность и смоченные поверхности. Все коллекторы образуются в процессе работы циркуляционного агрегата, рассмотренного в данной статье. Осаждение пылевых частиц из газа происходит в результате центробежных сил и вторичных циркуляций в направляющем канале, а также воздействия водяной завесы, жидкого барботажа и потока пылевого газа через капельно-брызговый слой. Дискуссии, обосновывающие возможность подтверждения влияния вязкости суспензии на эффективность процесса пылеулавливания, могут быть связаны как с анализом основных механизмов, влияющих на осаждение частиц на жидкие коллекторы, так и с условиями генерации коллекторов. При общей рециркуляции жидкости во влажном пылеулавливающем оборудовании повышается концентрация твердых веществ в жидкости. В таких условиях возможно постепенное снижение эффективности их обеспыливания. Эффект зависит от физико-химических свойств пыли, кинетической энергии частиц, типа используемого оборудования и, в частности, от способа организации контакта жидкой и газовой фаз. Исследования эффективности обеспыливания в зависимости от различных факторов приведены в следующей статье тех же авторов.

Ключевые слова: пылеуловители, эффективность пылеудаления, мокрые скрубберы

MECHANISMS OF TRAPPING FINE DUST IN WET DUST COLLECTING APPARATUS

J. Krawczyk, K. Kocewiak, J. Talaga, I. Postnikova

Janusz Krawczyk*, Katarzyna Kocewiak, Jan Talaga

Department of Industrial Equipment, Institute of Thermal and Process Engineering, Kracow University of Technology, Jana Pawła II st., 37, Kracow, 31-864, Poland

E-mail: jkrawczyk@pk.edu.pl*

Irina Postnikova*

Ivanovo State University of Chemistry and Technology, Sheremetev ave., 7, Ivanovo, 153000, Russia

E-mail: poirvic@mail.ru*

The high efficiency of intensive operation of wet scrubbers is the result of a simultaneous formation of different mechanisms of dust particle collectors. The collectors can be understood as droplets of atomised liquid, bubbles formed in the conditions of intensive barbotage, liquid surface and wet surfaces. All collectors are formed during the operation of the circulating unit. The deposition of dust particles from gas occurs as a result of centrifugal forces and secondary circulations in the guide duct as well as the effect of the water curtain, liquid barbotage and the flow of dusty

gas through the droplet-splash layer. Discussions substantiating the possibility of confirming the effect of suspension viscosity on the efficiency of the dust collection process can be related both to the analysis of basic mechanisms affecting the deposition of particles on liquid collectors and the conditions of generating collectors. In total liquid recirculation in wet dedusting equipment, concentration of solids in a liquid rises. In such conditions, a gradual decrease in their dedusting efficiency is possible. The effect depends on dust physiochemical properties, kinetic energy of particles, the type of equipment used, and specifically on the way of organization of the contact of the liquid and gas phases. Studies of the effectiveness of dedusting depending on various factors are given in the next article by the same authors.

Key words: dust collectors, dust removal efficiency, wet scrubbers

Для цитирования:

Кравчик Я., Кочевьяк К., Талага Я., Постникова И. Механизмы улавливания мелкодисперсной пыли во влажном пылеуловителе. *Изв. вузов. Химия и хим. технология.* 2019. Т. 62. Вып. 9. С. 97–101

For citation:

Krawczyk J., Kocewiak K., Talaga J., Postnikova I. Mechanisms of trapping fine dust in wet dust collecting apparatus. *Izv. Vyssh. Uchebn. Zaved. Khim. Khim. Tekhnol.* 2019. V. 62. N 9. P. 97–101

A method of predicting the particle removal efficiency of gravitational wet scrubbers and the particle size distribution properties, that considers diffusion, interception, and impaction, is presented to study the particle removal mechanisms of gravitational wet scrubbers [3].

Conventional scrubbers are typically modified to serve the needs of modern industries [4]. For example in literature [5] shows comprehensive analysis for prediction of dust removal efficiency using twin-fluid atomization in a spray scrubber. In article [6] is presented prediction for particle removal efficiency of a reverse jet scrubber. Numerical results were compared with the analytic results using average relative velocity in all zones and experimental results.

A pilot plant counter-current spray-column wet scrubber has been conceived, designed and fabricated. Experimental investigations were conducted to quantify the efficiency of a counter-current spray-column for scrubbing the particles from the gaseous waste stream [7].

Fly-ash removal efficiency in a modified multi-stage bubble column scrubber show in the literature [8]. It has been found that the present system yielded very high efficiency for the scrubbing of fly-ash. In most cases, the fly-ash removal efficiency is more than 95% and many cases approaches 99.5%.

Recent investigations with nozzle scrubbers show in article [9]. Different designs of scrubber will require different types of nozzles and spray properties to operate effectively. All parameters relevant for operation such as specific water consumption, residence time and specific energy consumption have been investigated in detail, and different pneumatic atomizing nozzles (with internal and external mixing of both phases) in various geometrical arrays are examined.

This paper [10] presents results obtained from a computer model which describes the removal of fine particles from gas streams in a wet scrubber. The simulation results show an improvement of the collection efficiency of submicron aerosol particles which is explained by the turbulent diffusion mechanism.

Wet scrubbing of polydisperse aerosols by freely falling droplets show in the literature [11]. In this study, analytical solutions for removal of a polydisperse aerosol by wet scrubbing were derived employing Brownian diffusion and inertial impaction as removal mechanisms.

A method of predicting the particle collection efficiency of a fixed valve tray column and the particle size distribution properties, which considers diffusion, interception, and impaction, is presented [12] to study the particle removal mechanisms of a fixed valve column.

If the concentration of solid particles in dust collection liquid reaches a critical value, over which the efficiency of the process decreases, we can then determine the maximum recirculation degree value – i.e. the recirculation threshold [13].

Discussions substantiating the possibility of confirming the effect of suspension viscosity on the efficiency of the dust collection process can be related both to the analysis of basic mechanisms affecting the deposition of particles, particle deposition on liquid collectors and the conditions of generating collectors.

All of mentioned collectors can be observed in a circulating scrubber unit [1], presented in Fig.1. The operation of the unit is similar to typical Roto-Clone Type N scrubbers [2, 14, 15-22] with one difference – the presented solution does not contain the so-called dirty chamber, moving it to the bottom part of the chamber.

Fig. 1 illustrates the scheme of the most common constructions of RotoClone type of circulating units. In these dust collectors the gas, which has been pre-cleaned in the so-called dirty chamber, flows together with dispersed drops of liquid through the guide duct and is then pressed under the liquid surface in the dust collection chamber.

Dielectric type dust collectors are included in the group of medium energy apparatus with hydraulic flow resistance lower than 350 dPa, allowing to obtain high dust removal efficiency. The lack of moving parts, the relatively high gas velocities and the large surfaces through which the gas is transported affect the high reliability and reliability of operation.

Fig. 2 a illustrates a scheme of the analysed unit. The dusted gas is fed into the unit through a rectangular duct (4) ending with a guide (5). It is directed below the surface of the liquid filling in the unit, and then it reaches the separating space in the unit (3) and through the drop separator/ mist eliminator (2) it is released outside. The sludge is periodically removed from the unit with the use of the outlet pipe (6).

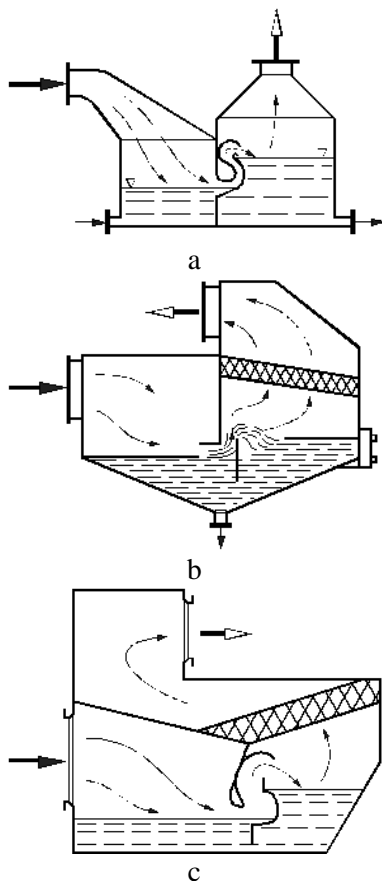

Fig. 1. Schemes of shock-inertial dust collectors a) Roto Clone scrubber, b), c) modified constructions of collectors
Рис. 1. Схемы ударно-инерционных пылеуловителей а) скруббер Рото-клон, б), в) модифицированные конструкции коллекторов

The analysed unit is intended to purify gas from small emission sources in the periodic operation system, i.e. periodic replacement of the dust collecting liquid. The time of unit operation is affected by the obtained operational efficiencies and hydraulic flow resistance. The periodic replacement of the liquid in the unit makes its operation simpler and, above all, determines a low indicator of water consumption per volume unit of a purified gas.

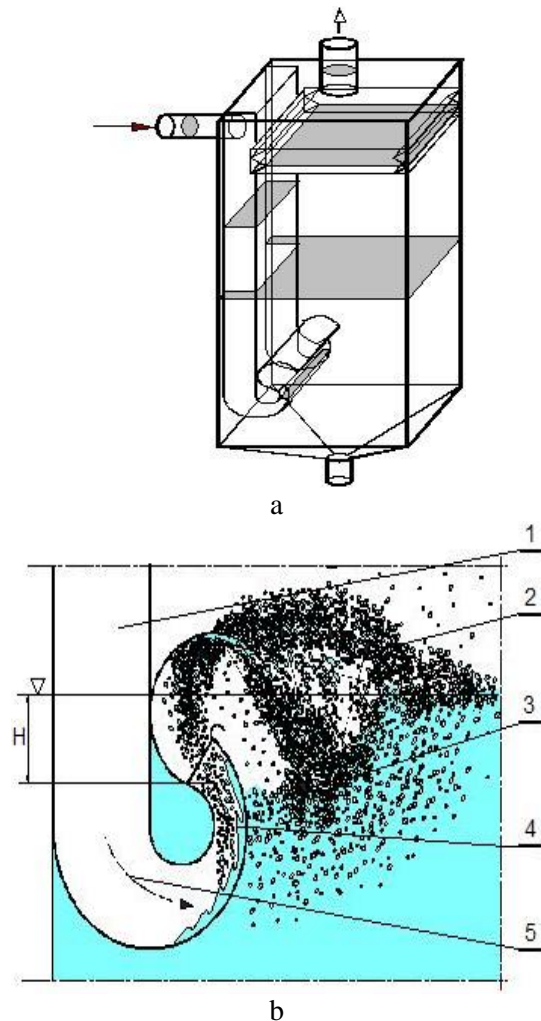

Fig. 2. Experimental unit and dust collection mechanism a - diagram of the tested unit, b - formation of dust collectors 1 – guide channel, 2 – droplet and splash layer, 3 – formation of the water curtain, 4 – water film in the guide channel, 5 – aerosol penetration into the liquid, H – fill level

Рис. 2. Экспериментальная установка и механизм захвата пыли а - схема испытываемого агрегата, б-образование коллекторов-пылеуловителей 1-направляющий канал, 2-капельный и брызговый слой, 3-образование водяной завесы, 4-водная пленка в направляющем канале, 5-проникновение аэрозоля в жидкость, H-уровень заполнения

Obviously, a lowered indicator of water consumption cannot be accompanied by a lowered dust removal efficiency, and it is justified to presume that the

given values guarantee the achievement of maximum efficiencies. Disregarding the fact that the indicator of water consumption is a rather imprecise parameter taking into account at least changeable conditions of gas humidification and its temperature, a different operational efficiency of mist eliminating devices, an influence of aerosol concentration on the amount of the solid particles retained in the apparatus and, consequently, the concentration and frequency of sludge removal, the demonstrated discrepancies are too large and indicate the need for experimental verification.

Depending on the aerosol velocity in the throat of the guide duct, the operating ranges of the unit have been distinguished, in which the dominant elements are:

- bubbling process at gas velocity within 8-12 m/s,
- bubbling and drip process corresponding to the velocity of 12-18 m/s,
- drip process corresponding to the velocity of 18-25 m/s.

In the 18-25 m/s speed range in the dust extractor, the phenomenon of transferring water from the dirty chamber to the separation part in the form of droplets was observed. The drops are entrained into the confusor and then into the narrowing, where the aerosol reaches its maximum velocity. Further shifting from the confusor to the curvature is associated with the reduction of the aerosol speed to 10-15 m/s. Acceleration of droplets in the narrowing occurs much slower than dust particles, which promotes the formation of a significant relative difference in velocity between drops and dust particles and increases the effect of the inertia collision mechanism.

Fig. 2a presents typical cross-section planes, resulting from the design of the unit taken from the unit design – their correct selection may be decisive to the correct operation of the unit.

Fig. 2b shows a schematic representation of dust collectors formed in the guide and the separation space of the unit [16]. The deposition of dust particles from gas occurs as a result of centrifugal forces and secondary circulations in the guide duct as well as the effect of the water curtain, liquid barbotage and the flow of dusty gas through the droplet-splash layer. It is, therefore, obvious that the correct operation of a unit depends on the velocity of the flowing aerosol and the H liquid level in the unit.

In total liquid recirculation in wet dedusting equipment, concentration of solids in a liquid rises. In such conditions, a gradual decrease of their dedusting efficiency is possible. The effect depends on dust physiochemical properties, kinetic energy of particles, the type of equipment used, and specifically on the way contact between liquid and gaseous phases is arranged [1].

Studies of the effectiveness of dedusting depending on various factors are given in the article: «Influence of the main factors on the efficiency of wet vortex dust collectors» of the same authors.

Статья публикуется при финансовой поддержке Российского фонда фундаментальных исследований в рамках реализации проекта №18-03-20102-г.

REFERENCES ЛИТЕРАТУРА

1. **Krawczyk J.** Development of wet methods of industrial gases dedusting on the basis of experimental investigations. Cracow, Poland: Cracow University of Technology Publisher. 2015. V. 19. N 4. P. 1-7 (in Polish).
2. **Krawczyk J., Dyląg M., Rosiński J.** Verminderung des wasserbedarfs bei der entstaubung. *Gefahrst. Reinhalt.* 1998. L. 59 (1). P. 45-49 (in Germany).
3. **Byeon S.H., Lee B.K., Mohan B.R.** Removal of ammonia and particulate matter using a modified turbulent wet scrubbing system. *Sep. Purif. Technol.* 2012. V. 98. P. 221-229. DOI: 10.1016/j.seppur.2012.07.014.
4. **Mohan Jain R., Meikap B.** Comprehensive analysis for prediction of dust removal efficiency using twin-fluid atomization in a spray scrubber. *Sep. Purif. Technol.* 2008. V. 63. N 2. P. 269-277. DOI: 10.1016/j.seppur.2008.05.006.
5. **Kim H., Jung C., Oh S., Lee K.** Particle removal efficiency of gravitational wet scrubber considering diffusion, interception and impaction. *Environ. Eng. Sci.* 2001. V. 18. N 2. P. 125-136. DOI: 10.1089/10928750151123257.
6. **Lim K., Lee S., Park H.** Prediction for particle removal efficiency of a reverse jet scrubber. *J. Aerosol. Sci.* 2006. V. 37. N 12. P. 1826-1839. DOI: 10.1016/j.jaerosci.2006.06.010.
7. **Mohan B., Biswas S., Meikap B.** Performance characteristics of the particulates scrubbing in a counter-current spray-column. *Sep. Purif. Technol.* 2008. V. 61. N 1. P. 96-102. DOI: 10.1016/j.seppur.2007.09.018.
8. **Meikap B., Biswas M.** Fly-ash removal efficiency in a modified multi-stage bubble column scrubber. *Sep. Purif. Technol.* 2004. V. 36. N 3. P. 177-190. DOI: 10.1016/S1383-5866(03)00213-2.
9. **Park S., Jung C., Jung K., Lee B., Lee K.** Wet scrubbing of polydisperse aerosols by freely falling droplets. *J. Aerosol. Sci.* 2005. V. 36. P. 1444-1458. DOI: 10.1016/j.jaerosci.2005.03.012.
10. **Wang Q., Chen X., Gong X.** The particle removing characteristics in a fixed valve tray column. *Ind. Eng. Chem. Res.* 2013. V. 52. N 9. P. 3441-3452. DOI: 10.1021/ie3027422.
11. **Krawczyk J.** Wet dedusting, heat and mass exchange in apparatuses of intense performance. Moscow, Russia: Russian National Academy Publisher. 1996.
12. **Talaga J., Brauer H., Dyląg M.** Modellvorstellung zur entstehung der vollständigen suspension im rühbehälter. *Forsch. Ingenieurwes.* 1996. V. 62. N 9. P. 239-246. DOI: 10.1007/BF02601430.
13. **Krawczyk J., Czagin O., Postnikowa I.** The change of fractional dedusting efficiency with increase of liquid concentration for different wettability dusts. In proceedings of IX International Conference "Theoretical Basics of Energy and Resource-saving Processes, Equipment and Environmentally Safe Industries", 28-30 September 2010. Ivanovo, Russia: Ivanovo State University of Chemistry and Technology Publisher. P. 121-128 (in Russia).

14. **Dłuska E., Hubacz R., Wroński S., Kamiński J., Dyląg M., Wójtowicz R.** The influence of helical flow on water fuel emulsion preparation. *Chem. Eng. Commun.* 2007. V. 194. N 10. P. 1271-1286. DOI: 10.1080/00986440701293959.
15. **Krawczyk J., Roszak Z., Wisła H.** Dedusting in bubbling and drop zones of periodic apparatus. *Chem. Eng. Equip.* 2006. V. 45. N 37. P. 99-101 (in Polish).
16. **Krawczyk J.** Change in dust collection efficiency of liquid collectors in conditions of dedusting liquid recirculation. *Pol. J. Chem. Tech.* 2017. V. 19. N 4. P. 1-7.
17. **Krawczyk J., Maszek L., Mieszkowski A., Roszak Z.** Wet dust extraction in the condition of total liquid recirculation. *Czasopismo Techniczne – Technical Transactions.* 2008. 2-M/2008 (2). P. 143-154 (in Polish).
18. **Krawczyk J., Czagin O., Postnikowa I.** Changes in the dust capture during the impact aerosol of the liquid surface. *Czasopismo Techniczne – Technical Transactions.* 2012. 2-M/2012 (6). P. 207-214 (in Polish).
19. **Szatko W., Bliniczew W., Krawczyk J.** Comparison of mathematical models describing changes of the suspension absorption capacity and thermal resistance of the sludge. In: *Process Engineering and Chemical Plant Design.* Ed. by G. Wozny, Ł. Hady. 2011. Berlin: Universitätsverlag der TU Berlin. P. 103-113.
20. **Wójtowicz R., Lipin A. A., Talaga J.** On the possibility of using of different turbulence models for modeling flow hydrodynamics and power consumption in mixing vessels with turbine impellers. *Theor. Found. Chem. Eng.* 2014. V. 48. N 4. P. 360-375. DOI: 10.1134/S0040579514020146
21. **Kamiński J., Wójtowicz R.** Drop size during dispersion of two immiscible liquids in a vibromixer. *Chem. Process Eng.* 2001. V. 22 (3C). P. 597-602 (in Polish).
22. **Wójtowicz R.** Choice of an optimal agitated vessel for the draw-down of floating solids. *Ind. Eng. Chem. Res.* 2014. V. 53. N 36. P. 13989-14001. DOI: 10.1021/ie500604q, 53 13989-14001.

*Поступила в редакцию 06.11.2018
Принята к опубликованию 30.07.2019*

*Received 06.11.2018
Accepted 30.07.2019*